

# TABLE OF CONTENTS

## Parts Manual VMC 2216 MODEL



COLUMN ASSEMBLY .....	2
10,000 RPM HEAD ASSEMBLY .....	4
BASE, SADDLE & TABLE ASSEMBLY .....	6
X-AXIS SCALE ASSEMBLY .....	8
Y-AXIS SCALE ASSEMBLY .....	9
DRAWBAR CYLINDER ASSEMBLIES.....	10
ORIENTATION BRIDGE ASSEMBLIES.....	11
IDLER ASSEMBLIES .....	12
WAY LUBE ASSEMBLY.....	14
GENEVA DRIVE ATC ASSEMBLY .....	16
SERVO DRIVE ATC ASSEMBLY .....	18
7500 RPM SPINDLE ASSEMBLY .....	20
10,000 RPM SPINDLE ASSEMBLY .....	21
COOLANT THROUGH SPINDLE.....	22
CNC CABINET ASSEMBLY .....	23
CARD CAGE ASSEMBLY .....	24
POWER JUNCTION CABINET ASSEMBLY .....	25
CHILLER CABINET ASSEMBLY .....	26
MP PENDANT ASSEMBLY .....	27
88HS PENDANT ASSEMBLY .....	28
FRONT DOOR ASSEMBLY .....	29
WAY COVER ASSEMBLIES .....	30
SHEETMETAL HOUSING.....	31
7500 RPM COOLANT TANK .....	32
7500 RPM COOLANT THROUGH TANK ASSEMBLY .....	33
10,000 RPM COOLANT TANK ASSEMBLY ASSEMBLY .....	34
10,000 RPM COOLANT THROUGH TANK ASSEMBLY.....	35



**This reference covers the following Fadal products:**

**Model VMC 2216**

Corporate Office..... voice (818) 407-1400 ..... fax (818) 407-0020  
Service / Parts ..... voice (818) 727-2100 ..... fax (818) 407-1004  
Programming Support ..... voice (818) 727-2100 ..... fax (818) 407-0061

support@fadal.com  
20701 Plummer Street, Chatsworth, California 91311 USA

The content of this manual has been reviewed for accuracy and is applicable to current Fadal hardware and software products as described herein. Differences may exist and we cannot guarantee that they are completely covered in this document. The information in this document is reviewed regularly and any necessary changes will be incorporated in the next revision. We welcome any suggestions for improvement.

Material is subject to change without notice.

This manual is for the exclusive use of Fadal Customers and Distributors. The reproduction, transmission or use of this document or its contents is not permitted without the expressed written permission of Fadal Machining Centers. All rights, including rights created by patent grant or registration of a utility, model or design, are reserved.

© Copyright 2002 Fadal Machining Centers.

# COLUMN ASSEMBLY

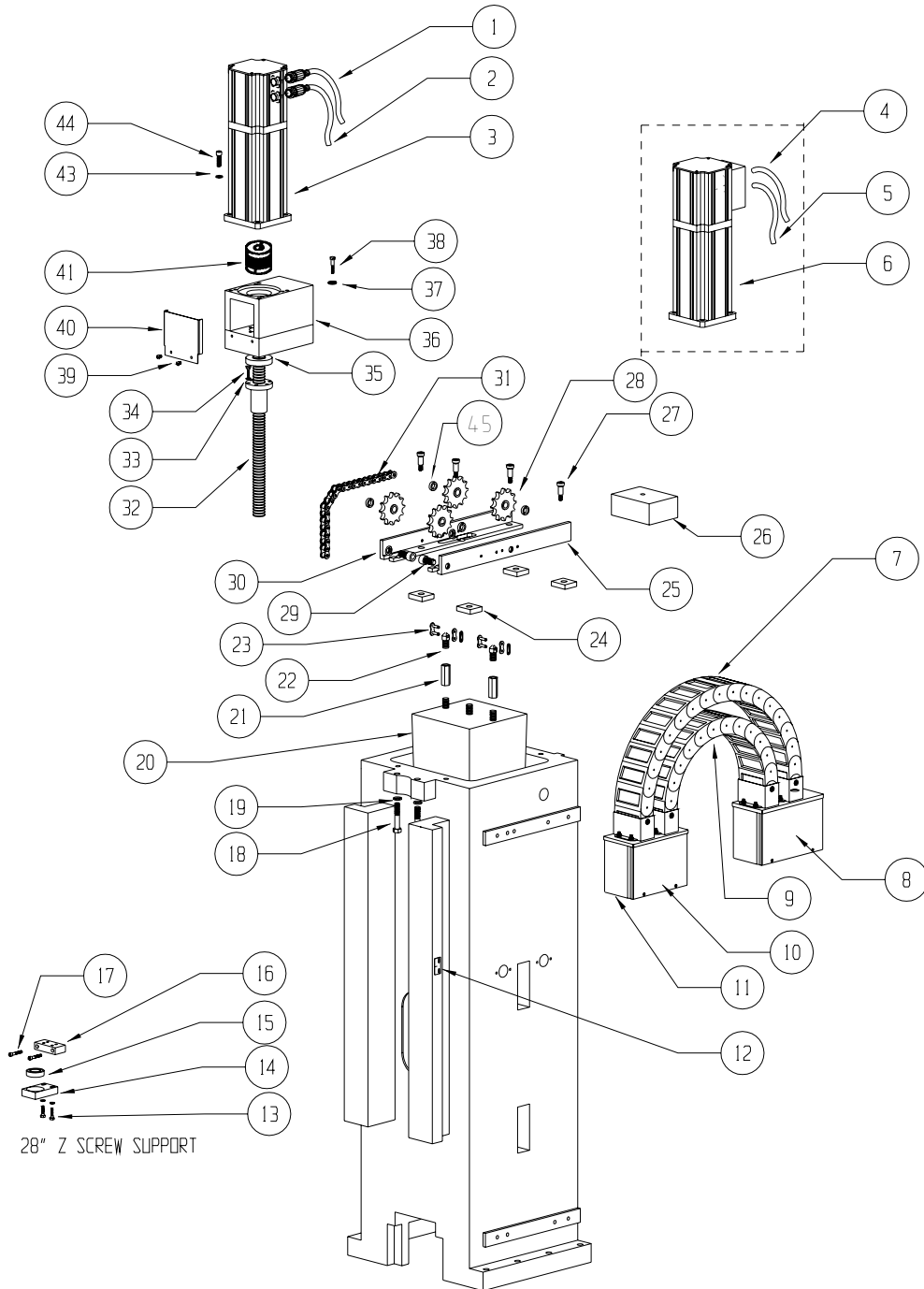

# COLUMN ASSEMBLY

## COLUMN ASSEMBLY

	PART #		PART #		PART #		PART #
1	WIR-0612	13	HDW-0317	24	HDW-0363	35	BLS-0105
2	WIR-0611		HDW-0048	25	CWT-0005	36	BLS-0032
3	MTR-0142	14	BLS-0042	26	CWT-0002	37	HDW-0049
4	WIR-0558	15	BRG-0023	27	HDW-0600	38	HDW-0315
5	WIR-0559	16	BLS-0041	28	PUL-0034	39	HDW-0347
6	MTR-0126	17	HDW-0297	29	HDW-0777	40	STM-0043
7	CVR-0074	18	HDW-0655	30	CWT-0007	41	MTR-0189
8	STM-0072	19	HDW-0050	31	HDW-0205	43	HDW-0280
9	CVR-0072	20	CWT-0018	32	BLS-0031 (20")	44	HDW-0779
10	STM-0300	21	HDW-0335		BLS-0024 (28")	45	CWT-0009
11	STM-0301	22	CWT-0001	33	HDW-0281		
12	STM-0044	23	HDW-0204	34	HDW-0319		

# 10K RPM HEAD ASSEMBLY

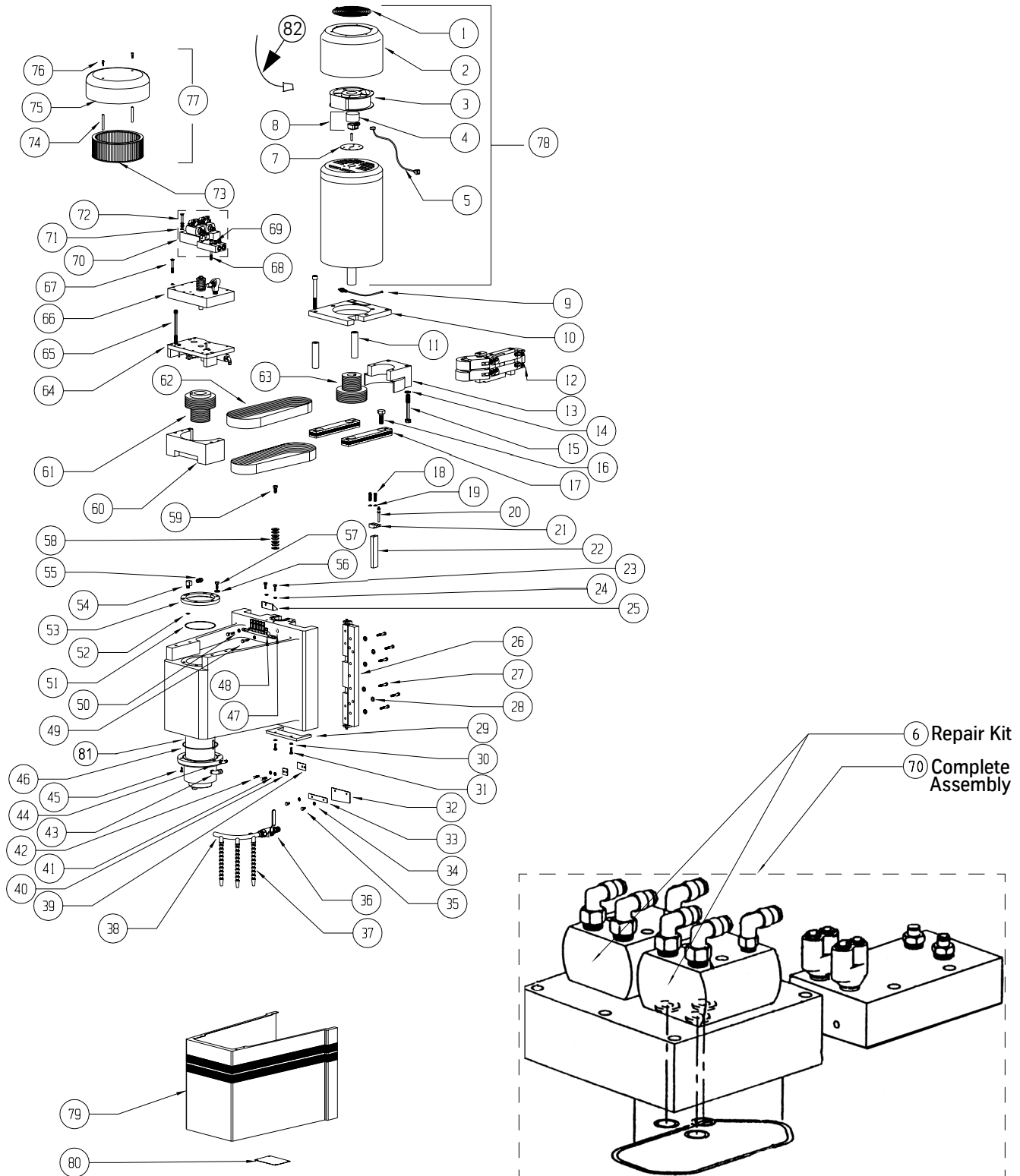

# 10K RPM HEAD ASSEMBLY

## 10K RPM HEAD ASSEMBLY

	PART #		PART #		PART #
1	HDW-0851	30	HDW-0279	59	HDW-0553
2	STM-0139	31	HDW-0322	60	BEL-0014
3	ELE-0124	32	HDW-0356	61	PUL-0018
4	MTR-0123	33	STM-0052	62	BEL-0024
5	WIR-0168	34	HDW-0279	63	PUL-0019
6	HYD-0018	35	HDW-0319	64	ORB-0001
7	STM-0148	36	VLV-0017	65	HDW-0290
8	ENC-0007	37	PLM-0016	66	DRB-0000
9	HDW-0369	38	CNT-0039	67	HDW-0320
10	MTR-0070	39	HDW-0294	68	HDW-0321 (HT)
11	MTR-0079	40	STM-0042	69	HDW-0279 (HT)
12	IDL-0002	41	HDW-0279	70	HYD-0017 (HT)
	IDL-0003(HT)				
13	BEL-0015	42	HDW-0294	71	HDW-0279 (HT)
14	HDW-0451	43	PLM-0112	72	HDW-0320 (HT)
15	HDW-0311	44	PLM-0034	73	MTR-0127
16	HDW-0283	45	HDW-0470	74	SVT-0108
17	MTR-0068	46	HDW-0181	75	STM-0467
	MTR-0064				
18	HDW-0294	47	HDW-0380	76	HDW-0597
19	HDW-0279	48	LUB-0045	77	MTR-0128
20	GIB-0013	49	HDW-0576	78	MTR-0045 <sup>(1)</sup>
21	GIB-0010	50	HDW-0279		MTR-0048 (HT)
22	GIB-0033	51	HDW-0148	79	CVR-0151
23	HDW-0320	52	HDW-0177	80	STM-0064
24	HDW-0279	53	SPN-0042	81	SPN-0007 <sup>(2)</sup>
25	STM-0141	54	PLM-0045	82	ATC-0093
26	GIB-0004	55	PLM-0088		
27	HDW-0569	56	HDW-0275		
28	HDW-0280	57	HDW-0568		
29	CVR-0048	58	HDW-0194		

<sup>1</sup>MTR-0045 INCLUDES: PUL-0019

<sup>2</sup>SPN-0007 INCLUDES: HDW-0181, HDW-0177, HDW-0148, PUL-0018.

(HT)=High Torque Option

# BASE, SADDLE & TABLE ASSEMBLY

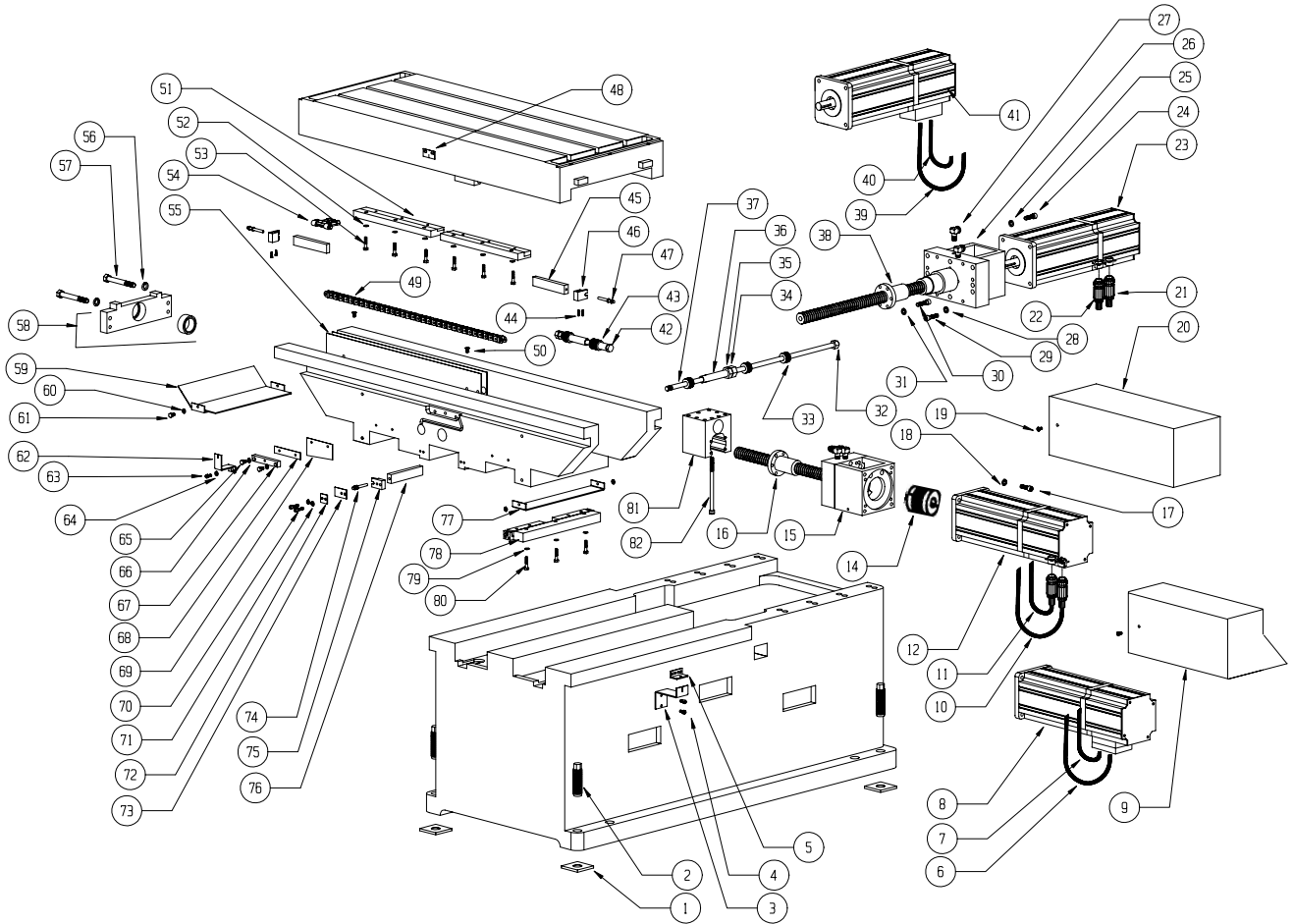



# BASE, SADDLE & TABLE ASSEMBLY

## BASE, SADDLE & TABLE ASSEMBLY

	PART #		PART #		PART #		PART #		PART #
1	SHP-0002	18	HDW-0280	35	HDW-0637	52	HDW-0312	69	HDW-0356
2	HDW-0374	19	HDW-0347	36	HDW-0219	53	HDW-0859	70	HDW-0295
3	STM-0112	20	STM-0609	37	BLS-0187	54	LUB-0044	71	HDW-0279
4	HDW-0295	21	WIR-0610	38	BLS-0029	55	STM-0075	72	STM-0042
5	STM-0047	22	WIR-0609	39	WIR-0557	56	HDW-0444	73	HDW-0355
6	WIR-0554	23	MTR-0142	40	WIR-0556	57	HDW-0311	74	GIB-0013
7	WIR-0555	24	HDW-0779	41	MTR-0126	58	BLS-0028	75	GIB-0010
8	MTR-0126	25	HDW-0280	42	HDW-0556	59	STM-0356	76	GIB-0001 <sup>(3)</sup>
9	STM-0575	26	BLS-0030	43	BLS-0142	60	HDW-0279	77	STM-0357
10	WIR-0608	27	PLM-0112	44	HDW-0296	61	HDW-0319	78	GIB-0005 <sup>(3)</sup>
11	WIR-0607	28	HDW-0444	45	GIB-0001 <sup>(3)</sup>	62	STM-0045	79	HDW-0279
12	MTR-0142	29	HDW-0564	46	GIB-0011	63	HDW-0319	80	HDW-0569
		30	HDW-0603	47	GIB-0013	64	HDW-0279	81	BLS-0077
14	MTR-0189 <sup>(1)</sup>	31	HDW-0472	48	STM-0044	65	HDW-0294	82	HDW-0572
15	BLS-0027	32	HDW-0332	49	CVR-0038	66	HDW-0279		
16	BLS-0026 <sup>(2)</sup>	33	HDW-0194	50	HDW-0319	67	SDL-0007		
17	HDW-0779	34	HDW-0018	51	GIB-0006 <sup>(3)</sup>	68	STM-0052		

<sup>1</sup>Part of X and Y axes.

<sup>2</sup>Complete ballscrew assembly with bearing mount.

<sup>3</sup>Specify gib size when ordering.

# X-AXIS SCALE ASSEMBLY

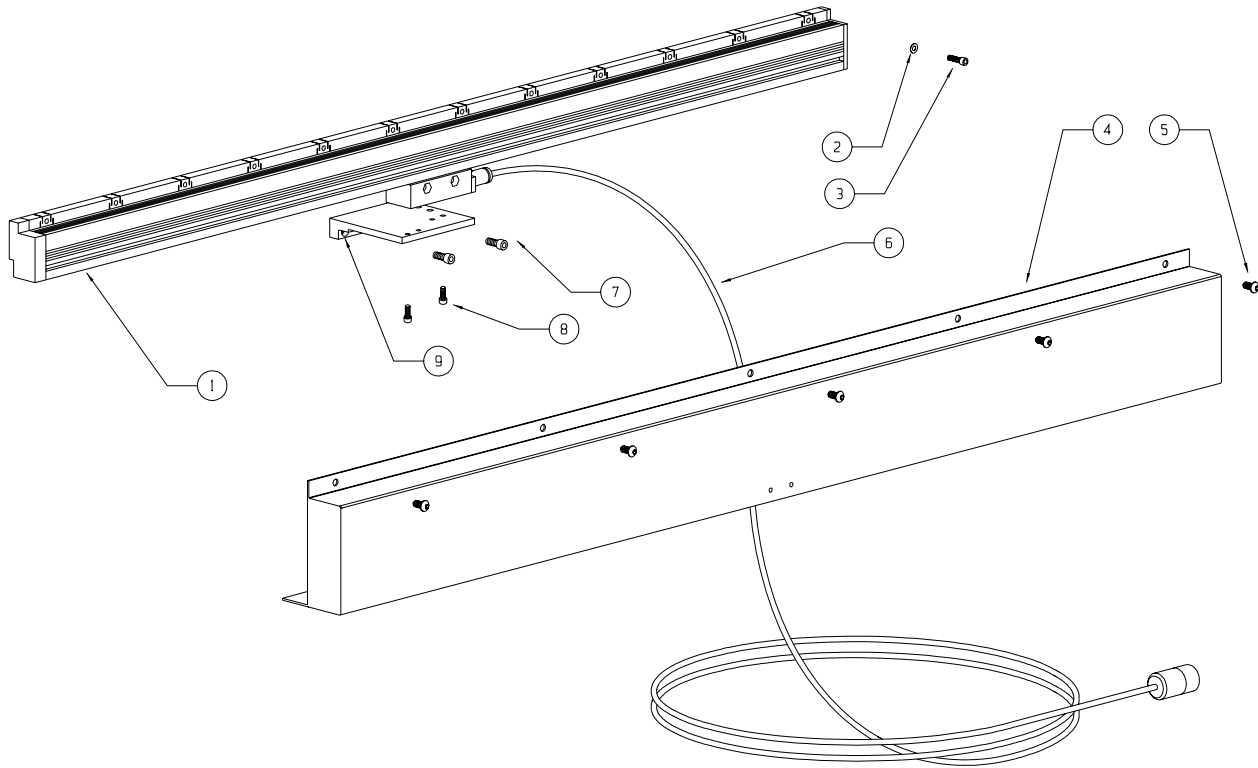

**X-AXIS SCALE ASSEMBLY**

	PART #		PART #
1	SCL-0025	6	SCL-0029
2	HDW-0281	7	HDW-0291
3	HDW-0797	8	HDW-0282
4	STM-0396	9	SCL-0036
5	HDW-0346		

# Y-AXIS SCALE ASSEMBLY

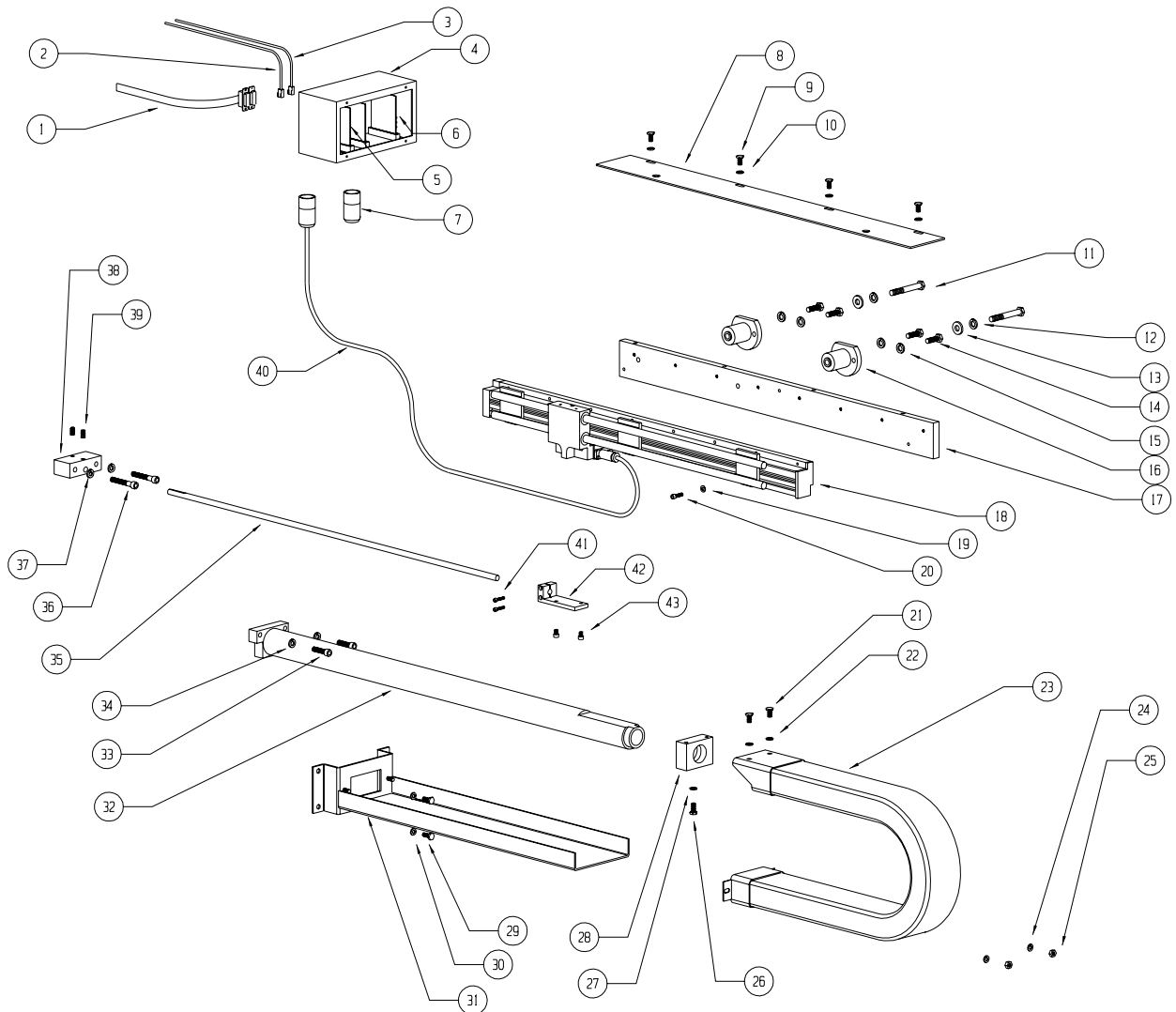

Y-AXIS SCALE ASSEMBLY

	PART #		PART #		PART #		PART #		PART #
1	WIR-0509	9	HDW-0295	17	STM-0177	25	HDW-0581	33	HDW-0291
2	WIR-0506	10	HDW-0279	18	SCL-0002	26	HDW-0319	34	HDW-0279
3	WIR-0134	11	HDW-0311	19	HDW-0279	27	HDW-0281	35	SCL-0046
4	SCL-0006	12	HDW-0281	20	HDW-0297	28	SCL-0039	36	HDW-0488
5	PCB-0050	13	HDW-0444	21	HDW-0319	29	HDW-0482	37	HDW-0279
6	PCB-0170	14	HDW-0314	22	HDW-0279	30	HDW-0279	38	SCL-0045
7	SCL-0018	15	HDW-0281	23	CVR-0009	31	STM-0178	39	HDW-0408
8	STM-0179	16	SCL-0042	24	HDW-0281	32	SCL-0063	40	SCL-0029

# DRAWBAR CYLINDER ASSEMBLY

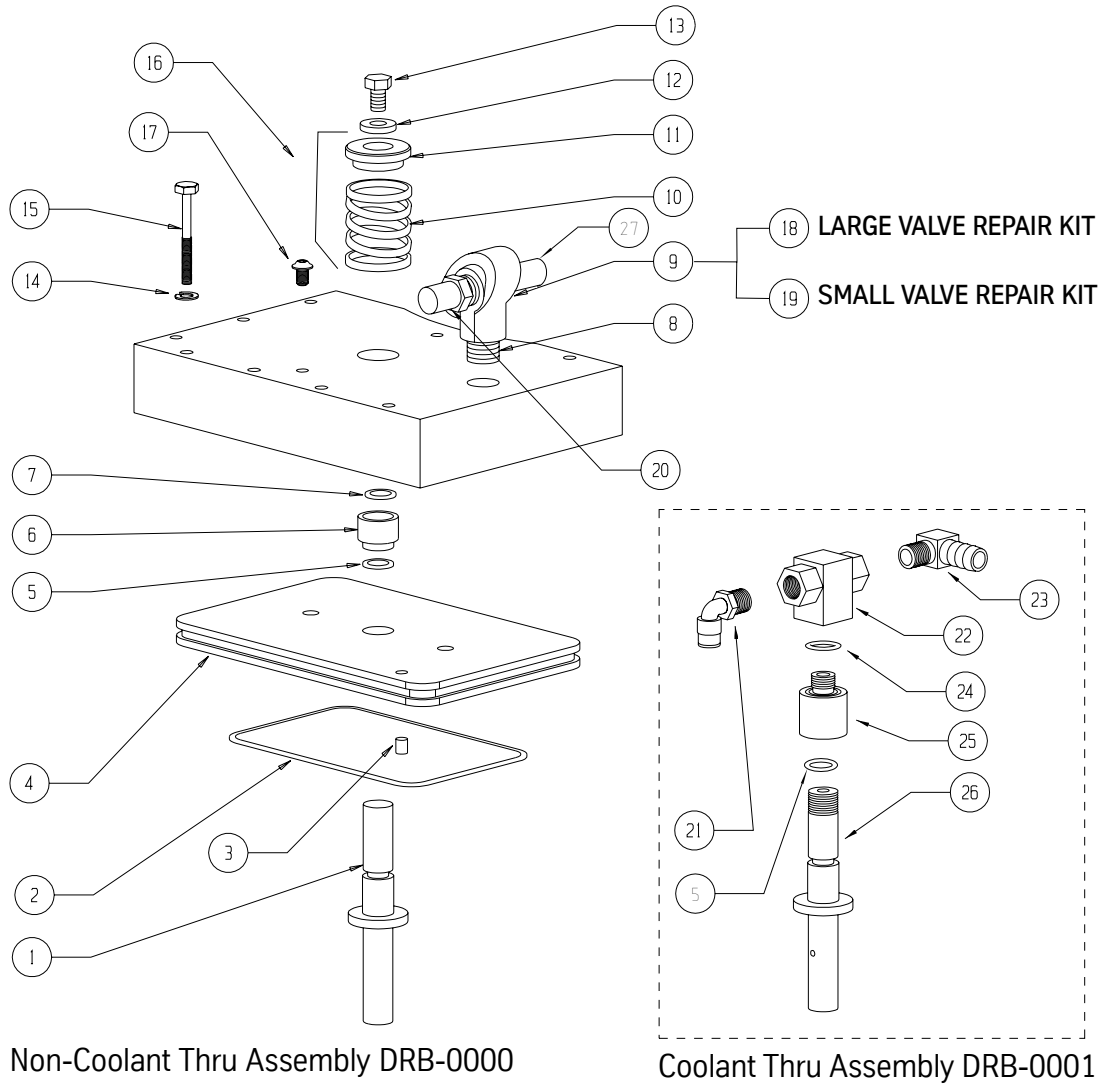

## DRAWBAR CYLINDER ASSEMBLIES

	PART #		PART #		PART #		PART #
1	DRB-0007	8	PLM-0117	15	HDW-0320	22	VLV-0021
2	HDW-0178	9	VLV-0031	16	HDW-0197	23	PLM-0105
3	ELE-0147	10	HDW-0262	17	HDW-0347	24	HDW-0150
4	DRB-0009 <sup>(1)</sup>	11	DRB-0017	18	VLV-0032	25	CNT-0046
5	HDW-0177	12	HDW-0048	19	VLV-0033	26	DRB-0008
6	DRB-0023	13	HDW-0575	20	PLM-0083	27	PLM-0030
7	HDW-0917	14	HDW-0279	21	PLM-0037		

<sup>1</sup>Includes ELE-0147

# ORIENTATION BRIDGE ASSEMBLY

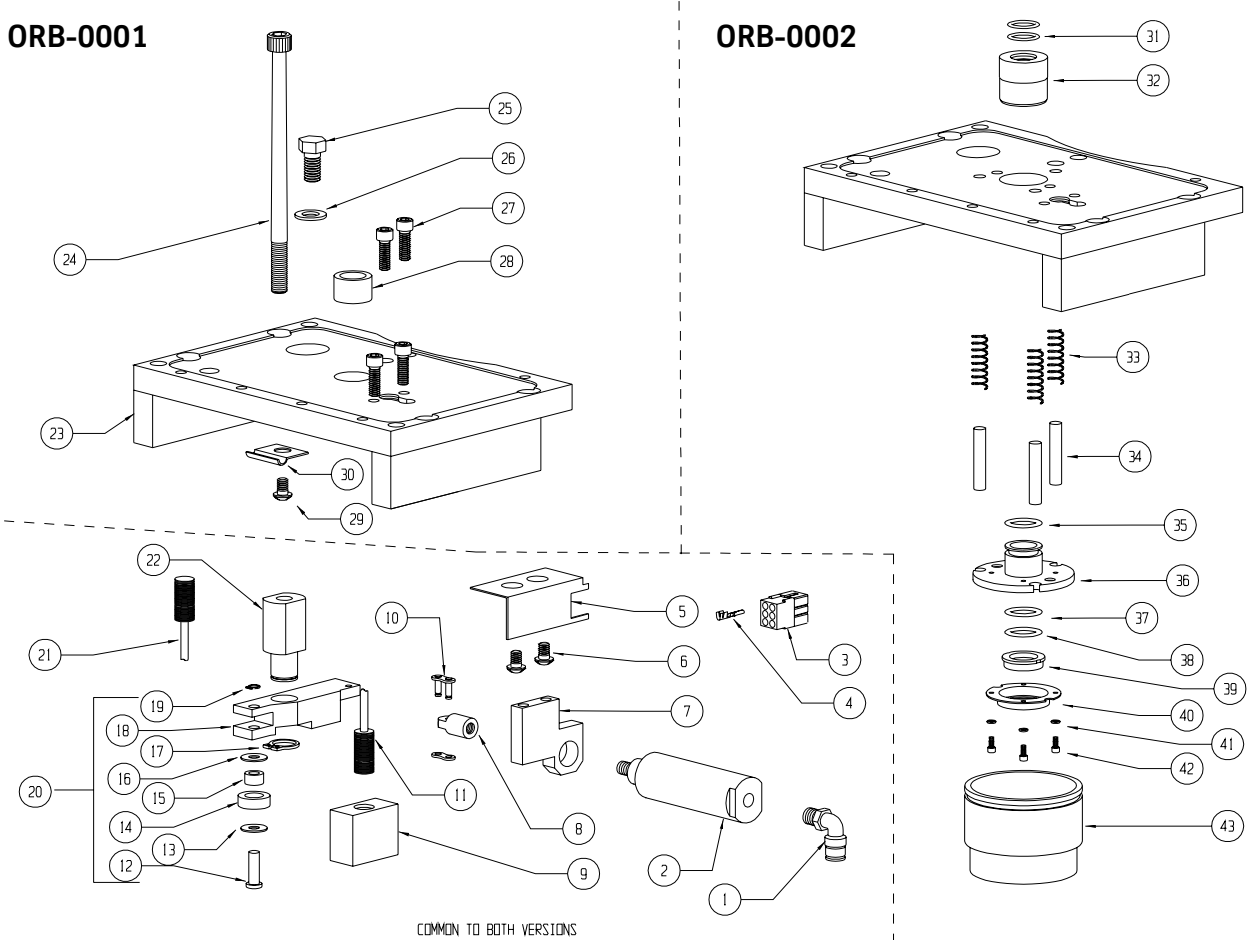

COMMON TO BOTH VERSIONS

### ORIENTATION BRIDGE ASSEMBLIES

	PART#		PART#		PART#		PART#		PART#
1	PLM-0034	8	ORB-0011	18	ORB-0031	28	BRG-0008	38	HDW-0156
2	CYL-0007	9	ORB-0014	19	HDW-0726	29	HDW-0349	39	CNT-0033
3	WIR-0051	10	HDW-0209	20	ORB-0004	30	LUB-0077	40	CNT-0045
4	WIR-0043 (16 AWG)	11	ELE-0145	21	ELE-0145	31	HDW-0150	41	HDW-0453
	WIR-0044 (16 AWG)	12	ORB-0007	22	ORB-0013	32	CNT-0042	42	HDW-0308
	WIR-0544 (22 AWG)	13	HDW-0515	23	ORB-0008	33	HDW-0257	43	CNT-0140
	WIR-0056 (22 AWG)	14	ORB-0009	24	HDW-0285	34	HDW-0326		
5	STM-0596	15	BRG-0014	25	HDW-0571	35	HDW-0156		
6	HDW-0347	16	HDW-0515	26	HDW-0048	36	CNT-0041		
7	ORB-0030	17	HDW-0725	27	HDW-0298	37	HDW-0155		

# IDLER ASSEMBLY

## RIGID TAP/HIGH TORQUE OPTION

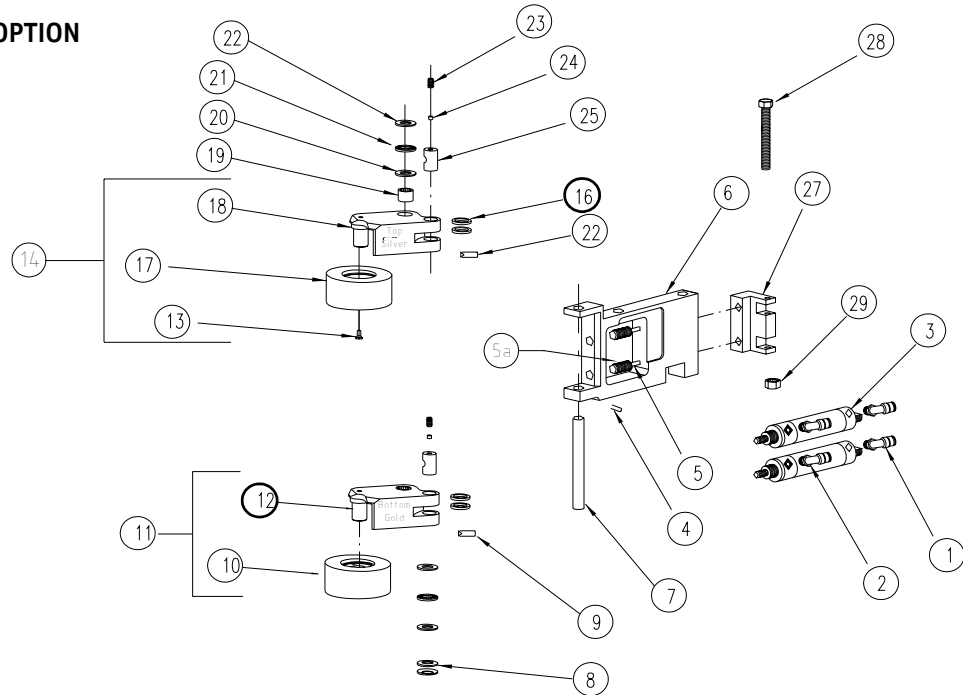

## 10,000 RPM OPTION

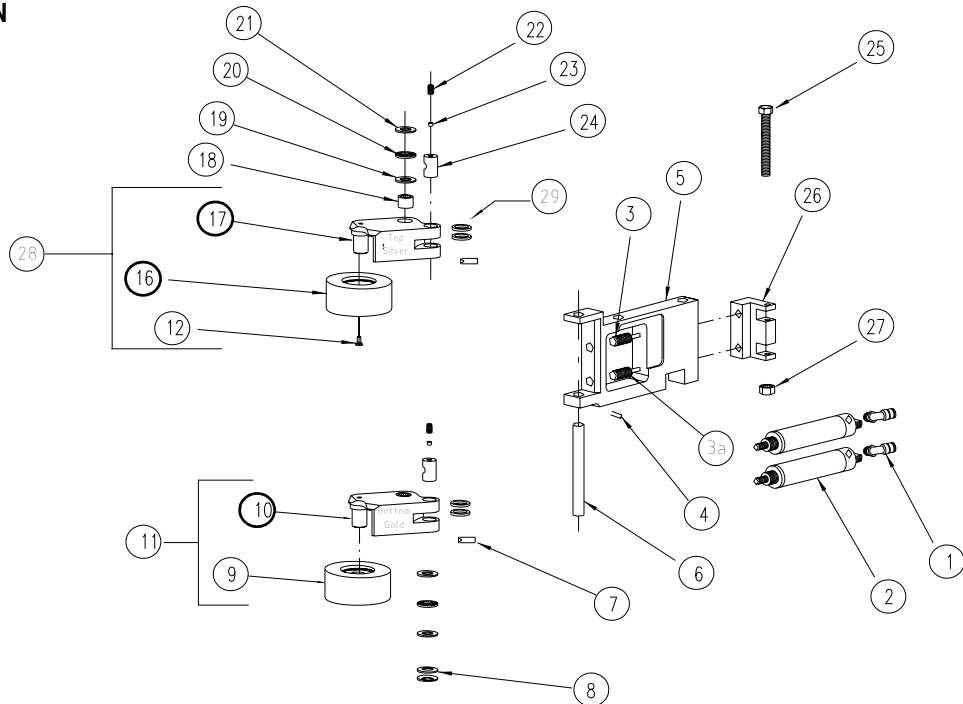

# IDLER ASSEMBLY

## RIGID TAP/HIGH TORQUE OPTION

	PART #		PART #		PART #
1	PLM-0034	10	BRG-0058	21	BRG-0015
2	PLM-0034	11	IDL-0000	22	ELE-0147
3	CYL-0005	12	IDL-0004	23	HDW-0412
4	HDW-0612	13	HDW-0412	24	IDL-0010
5	ELE-0145	14	IDL-0018	25	IDL-0012
5a	ELE-1202	16	HDW-0277		
6	IDL-0011	17	BRG-0058	27	IDL-0009
7	IDL-0006	18	IDL-0005	28	HDW-0579
8	HDW-0196	19	BRG-0017	29	HDW-0643
9	ELE-0147	20	BRG-0016		

## 10,000 RPM OPTION

	PART #		PART #		PART #
1	PLM-0034	10	IDL-0004	21	BRG-0016
2	CYL-0006	11	IDL-0000	22	HDW-0412
3	ELE-0145	12	HDW-0605	23	IDL-0010
3a	ELE-1202			24	IDL-0012
4	HDW-0612			25	HDW-0579
5	IDL-0011	16	BRG-0058	26	IDL-0008
6	IDL-0006	17	IDL-0005	27	HDW-0643
7	ELE-0147	18	BRG-0017	28	IDL-0018
8	HDW-0196	19	BRG-0016	29	HDW-0277
9	BRG-0058	20	BRG-0015		

# WAY LUBE ASSEMBLY

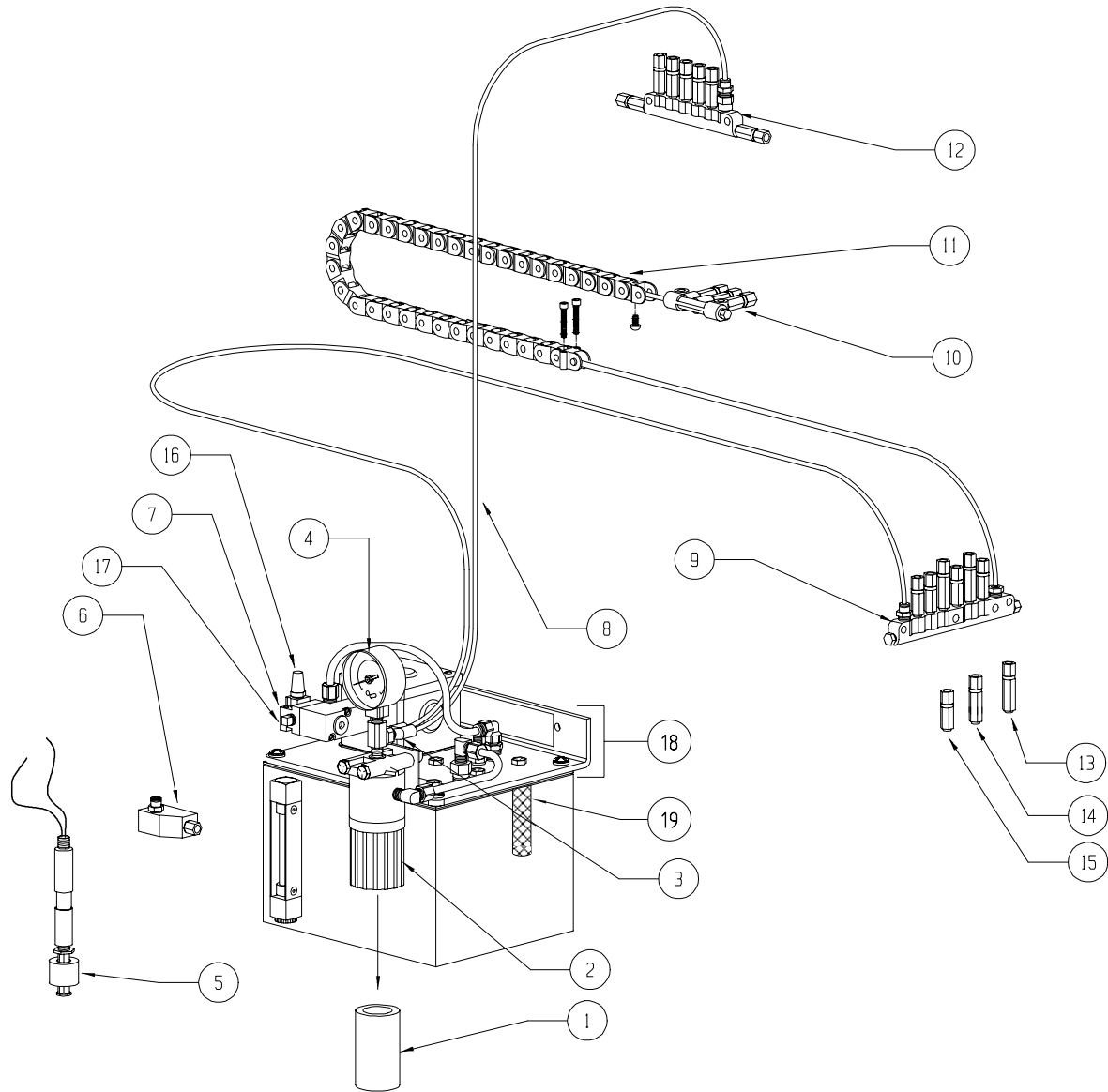

**WAY LUBE ASSEMBLY**

	PART #		PART #		PART #		PART #
1	LUB-0049	7	VLV-0028	13	LUB-0085	19	HDW-1039
2	LUB-0050	8	PLM-0022	14	LUB-0084		
3	PLM-0048	9	LUB-0041	15	LUB-0083		
4	REG-0018	10	LUB-0044	16	PLM-0084		
5	LUB-0036	11	CVR-0041	17	PLM-0036		
6	LUB-0051	12	LUB-0045	18	LUB-0038		





This page intentionally left blank.



# GENEVA DRIVE ATC ASSEMBLY

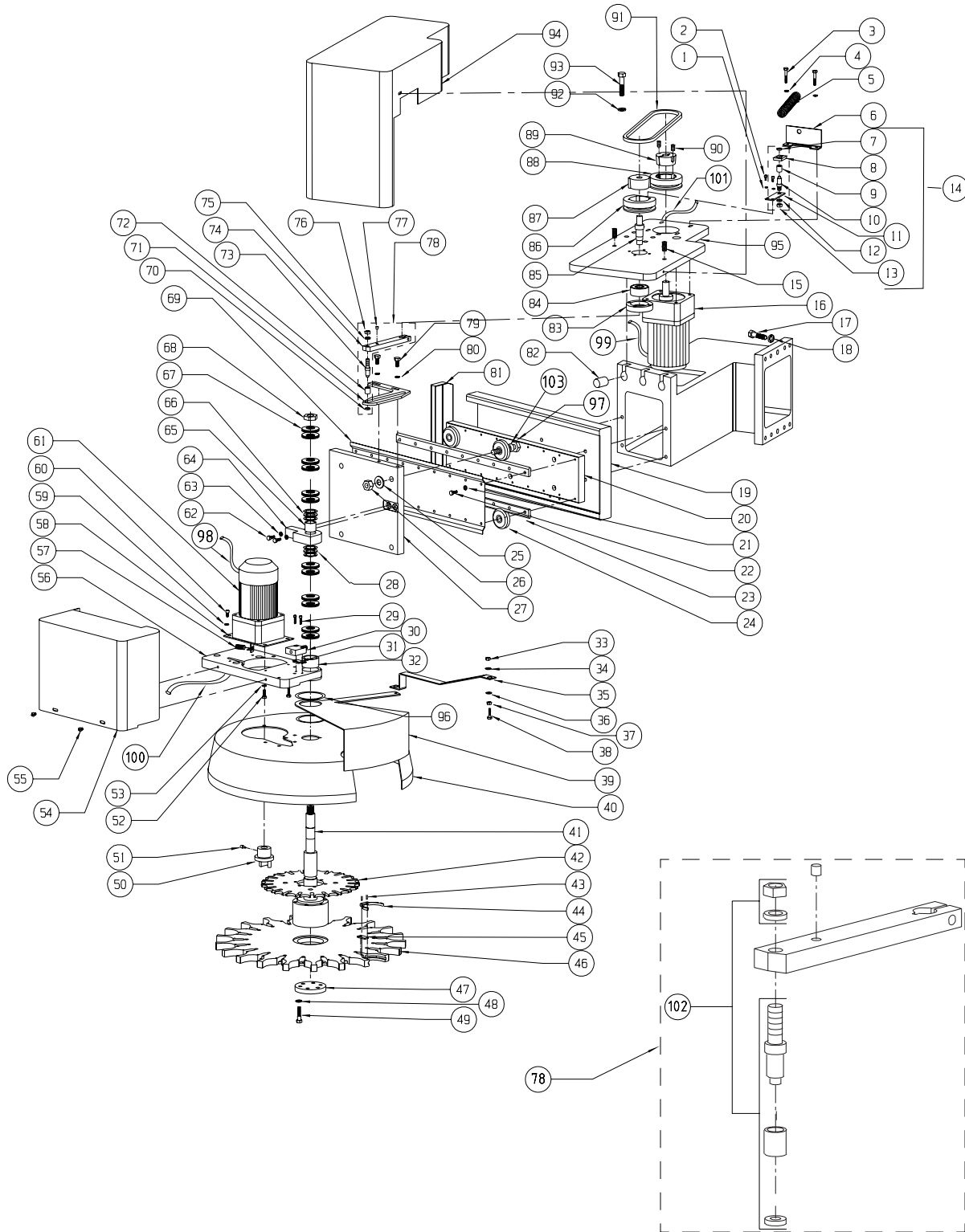

# GENEVA DRIVE ATC ASSEMBLY

## GENEVA DRIVE ATC ASSEMBLY

	PART #		PART #		PART #		PART #		PART #
1	HDW-0458	21	HDW-0279	41	ATC-0027	61	MTR-0134	82	ATC-0035
2	HDW-0304	22	HDW-0322	42	ATC-0025 (21)	62	HDW-0317	83	BLS-0040
3	HDW-0582	23	BRG-0034		ATC-0026 (30)	63	HDW-0281	84	BRG-0006
4	HDW-0279	24	BRG-0033	43	HDW-0328	64	*	85	ATC-0076
5	HDW-0259	25	HDW-0051	44	ATC-0028 (CAT)	65	BRG-0011	86	PUL-0029
6	STM-0291	26	HDW-0634		ATC-0029 (BT)	66	BRG-0010	87	PUL-0031
7	HDW-0443	27	*	45	ATC-0032	67	HDW-0193	88	PUL-0002
8	ATC-0077	28	BRG-0009	46	ATC-0009 (21)	68	HDW-0637	89	PUL-0003
9	BRG-0013	29	HDW-0771		ATC-0010 (21BT)	69	STM-0062	90	HDW-0400
10	ATC-0078	30	ELE-0385		ATC-0011 (30)	70	HDW-0047	91	BEL-0001
11	STM-0290	31	STM-0615		ATC-0012 (30BT)	71	ATC-0017	92	HDW-0451
12	HDW-0454	32	BRG-0012	47	ATC-0031	72	BRG-0013	93	HDW-0786
13	HDW-0640	33	HDW-0643	48	HDW-0280	73	ATC-0021	94	STM-0302
14	ATC-0013	34	HDW-0443	49	HDW-0313	74	ATC-0280	95	ATC-0059
15	ELE-1202	35	STM-0119	50	ATC-0023	75	HDW-0333	96	HDW-0357 .062
16	MTR-0133	36	HDW-0443	51	ELE-0786	76	HDW-0640		HDW-0358 .005
17	HDW-0310	37	HDW-0336	52	HDW-0583	77	ELE-0147		HDW-0359 .010
18	HDW-0451	38	HDW-0318	53	HDW-0279	78	ATC-0006	97	ATC-0033
19	STM-0061	39	STM-0033 (30)	54	STM-0292	79	HDW-0575	98	WIR-0724
20	ATC-0030		STM-0031 (21)	55	HDW-0347	80	HDW-0387	99	WIR-0723
		40	STM-0032 (30)	56	*	81	STM-0063	100	WIR-0648 <sup>(1)</sup>
			STM-0030 (21)	57	ELE-0145			101	WIR-0647 <sup>(1)</sup>
				58	ATC-0074			102	ATC-0169
				59	HDW-0279			103	ATC-0093
				60	HDW-0319 (3)			*	Sold as Assembly
					HDW-0295 (1)				ATC-0004 (21)
									ATC-0005 (30)

<sup>1</sup>Quick disconnect type

# SERVO DRIVE ATC ASSEMBLY

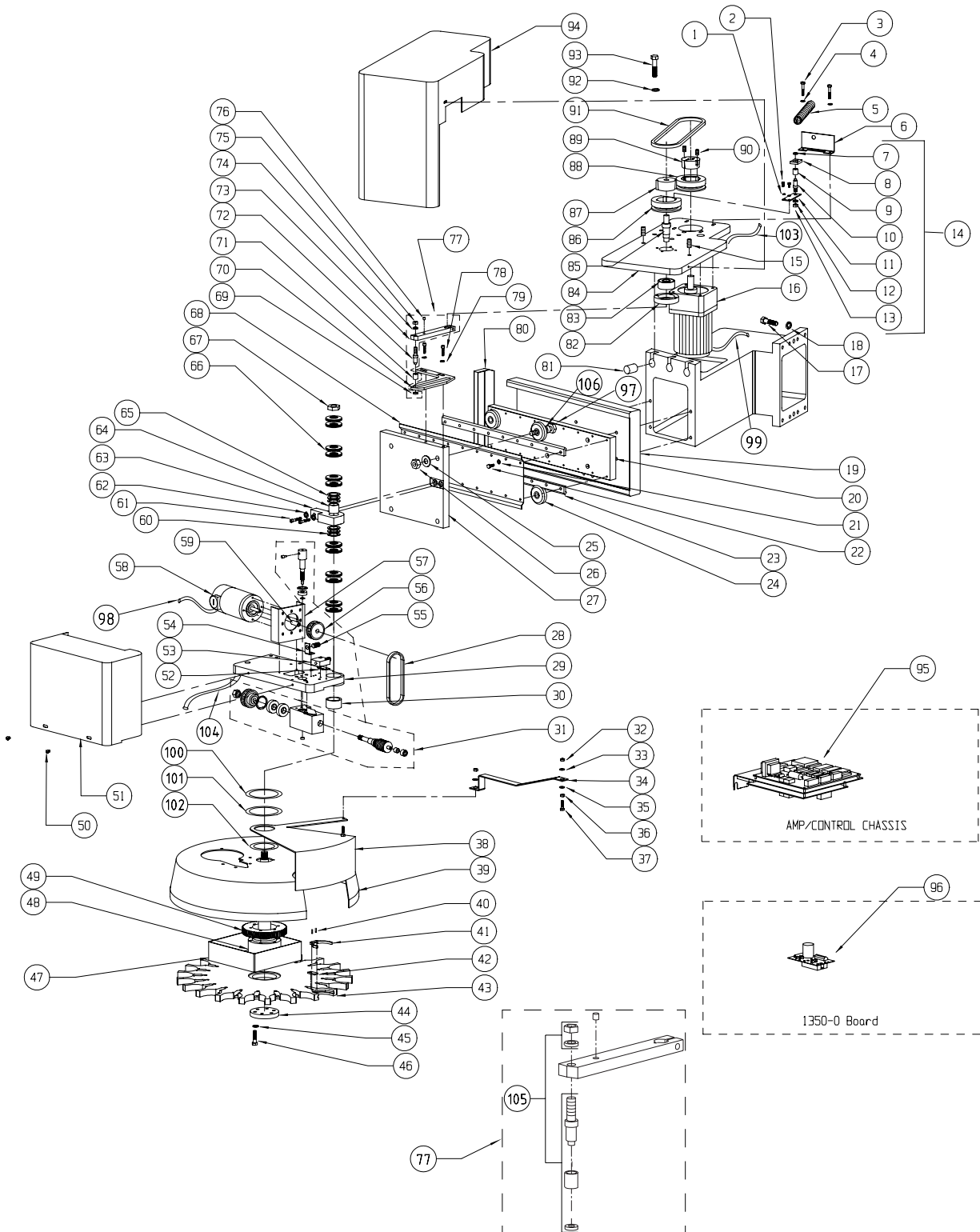

# SERVO DRIVE ATC ASSEMBLY

## SERVO DRIVE ATC ASSEMBLY

	PART #		PART #		PART #		PART #		PART #
1	HDW-0458	21	HDW-0279	41	ATC-0029 (BT)	61	HDW-0317	86	PUL-0029
2	HDW-0304	22	HDW-0322		ATC-0028 (CAT)	62	HDW-0281	87	PUL-0031
3	HDW-0582	23	BRG-0034	42	ATC-0032	63	*	88	PUL-0002
4	HDW-0279	24	BRG-0033	43	ATC-0009 (21)	64	BRG-0011	89	PUL-0003
5	HDW-0259	25	HDW-0051		ATC-0010 (21BT)	65	BRG-0010	90	HDW-0400
6	STM-0291	26	HDW-0634		ATC-0011 (30)	66	HDW-0193	91	BEL-0001
7	HDW-0443	27	*		ATC- 0012 (30)	67	HDW-0637	92	HDW-0451
8	ATC-0077	28	BEL-0018	44	ATC-0031	68	STM-0062	93	HDW-0789
9	BRG-0013	29	*	45	HDW-0280	69	HDW-0047	94	STM-0302
10	ATC-0078	30	BRG-0012	46	HDW-0313	70	ATC-0017	95	PCB-0108
11	STM-0290	31	ATC-0016	47	STM-0144 (21)	71	BRG-0013	96	PCB-0173
12	HDW-0454	32	HDW-0643		ATC-0091 (30)	72	ATC-0021	97	ATC-0033
13	HDW-0640	33	HDW-0443	48	ATC-0027	73	ATC-0020	98	WIR-0724
14	ATC-0013	34	STM-0019	49	ATC-0036 (21)	74	HDW-0280	99	WIR-0723
15	ELE-1202	35	HDW-0443		ATC-0037 (30)	75	HDW-0333	100	HDW-0357 .062
16	MTR-0133	36	HDW-0336	50	HDW-0347	76	ELE-0147	101	HDW-0358 .005
17	HDW-0310	37	HDW-0318	51	STM-0292	77	ATC-0006	102	HDW-0359 .010
18	HDW-0451	38	STM-0033 (30)	52	STM-0615	78	HDW-0575	103	WIR-0647
19	STM-0061		STM-0031 (21)	53	ELE-0385	79	HDW-0387	104	WIR-0649
20	ATC-0030	39	STM-0032 (30)	54	STM-0147	80	STM-0063	105	ATC-0169
			STM-0030 (21)	55	ELE-0145	81	ATC-0035	106	ATC-0093
		40	HDW-0328	56	PUL-0008	82	BLS-0040		
				57	ATC-0088	83	BRG-0006		
				58	MTR-0144	84	ATC-0058 (21)	*	Sold as Assembly
				59	OBSOLETE		ATC-0059 (30)		ATC-0056 (21)
				60	BRG-0009	85	ATC-0076		ATC-0055 (30)

# 7500 RPM SPINDLE ASSEMBLY

**7500 RPM SPINDLE ASSEMBLY**

	PART #
1	SPN-0079
2	DRB-0019
3	HDW-0195
4	SPN-0084
5	DRB-0004
6	BRG-0005
7	DRB-0028 <sup>(1)</sup>
8	BRG-0005
ASSY SPN-0037 <sup>(2)</sup>	

<sup>1</sup>Not sold individually. Sold as assembly DRB-0030 (includes DRB-0028 and SPN-0079)

<sup>2</sup>Assembly includes all parts listed on this page plus PUL-0025

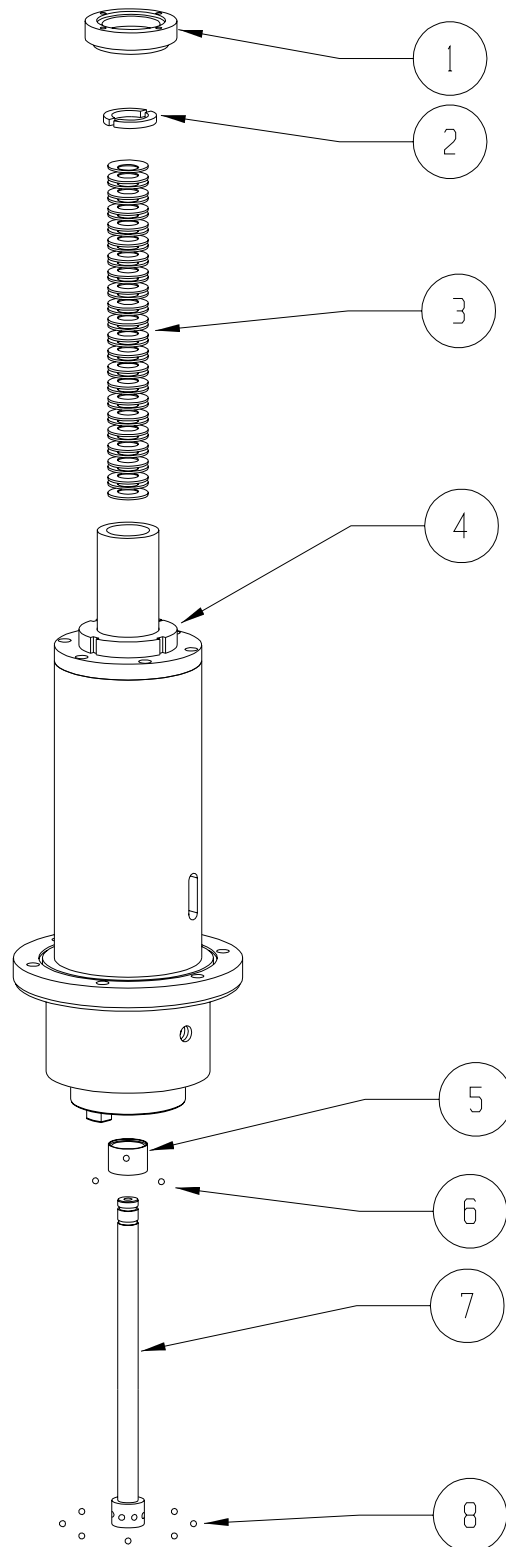

# 10K RPM SPINDLE ASSEMBLY

## 10,000 RPM SPINDLE ASSEMBLY

	PART #
1	HDW-0177
2	HDW-0307
3	DRB-0015
4	HDW-0180
5	DRB-0019
6	DRB-0014
7	BRG-0004
8	DRB-0016
9	HDW-0158
10	HDW-0195
11	SPN-0084
12	DRB-0004
13	BRG-0005
14	DRB-0026 <sup>(1)</sup>
15	BRG-0005
16	HDW-0155
17	HDW-0181
18	PLM-0034
ASSY SPN-0007 <sup>(2)</sup>	

<sup>1</sup>Not sold separately. Sold with assembly DRB-0003 (includes pieces 1-9, 14 & 15).

<sup>2</sup>Assembly includes all parts listed on this page plus PUL-0020.

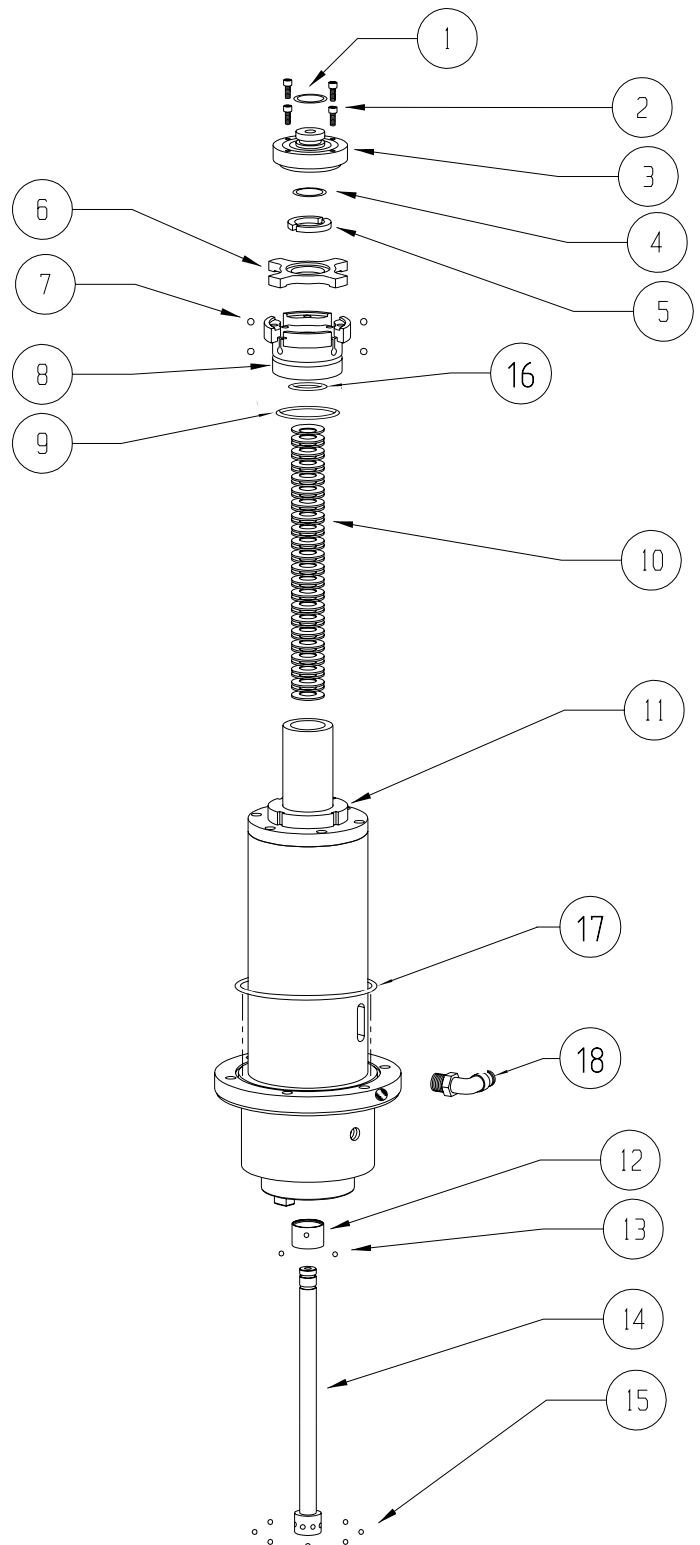

# COOLANT THROUGH SPINDLE

CNT-0015, Coolant-thru Seal Conversion Kit  
 CNT-0150, Seal Repair Kit

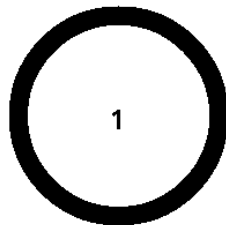

1  
HDW-0158



2  
HDW-0177



3  
HDW-0150

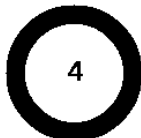

4  
HDW-0917

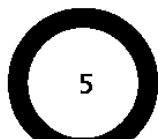

5  
HDW-1102

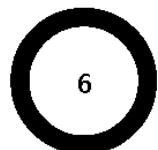

6  
HDW-0156

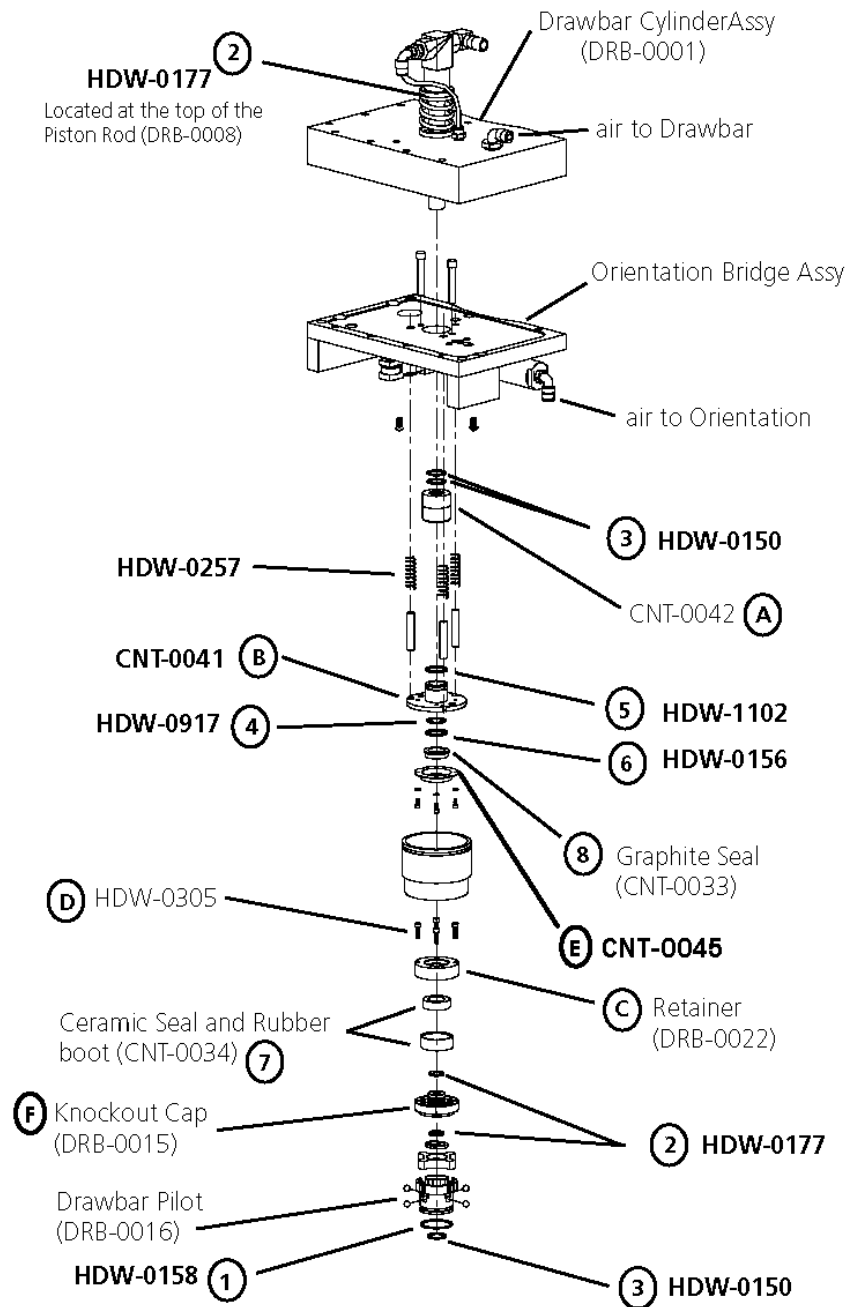

CNT-0150 O-RINGS AND SEALS ONLY (1-8)  
 CNT-0015 FOR CONVERTING OLDER MODELS (1-8  
 AND A-F)



# CNC CABINET ASSEMBLY

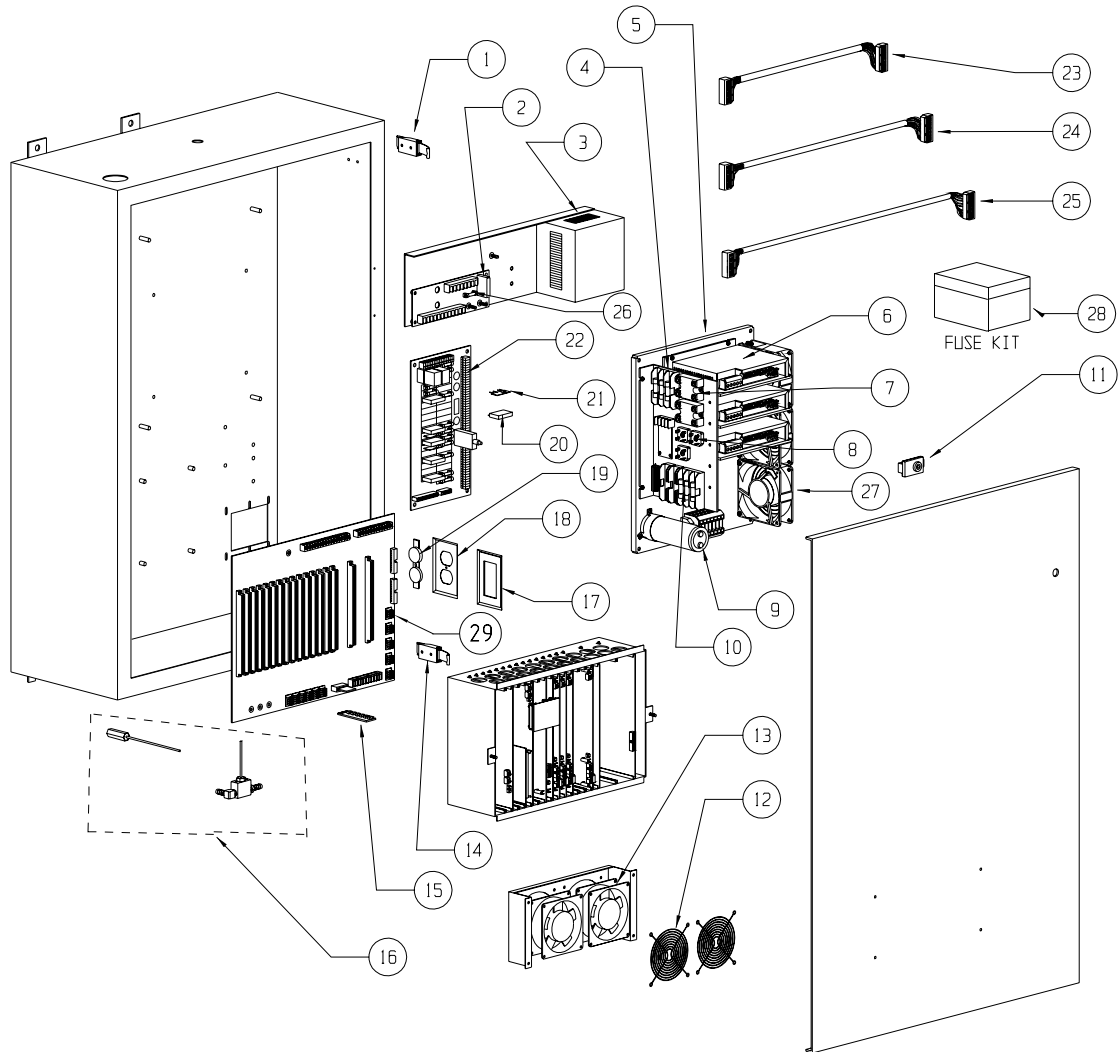

**CNC CABINET ASSEMBLY**

	PART #		PART #		PART #		PART #
1	HDW-0220	8	ELE-0828	15	PCB-0010	22	PCB-0194
2	ELE-0071	9	AMP-0036	16	CNT-0022	23	WIR-0161
3	ELE-0961	10	ELE-0840	17	WIR-0120	24	WIR-0163
4	ELE-0837	11	HDW-0221	18	WIR-0120	25	WIR-0174
5	AMP-0028 (GTK)	12	HDW-0850	19	WIR-0121	26	ELE-0046
	AMP-0033 (AMC)	13	ELE-0123	20	ELE-0070	27	ELE-0123
6	AMP-0029 (GTK)	14	HDW-0217	21	ELE-0101	28	ELE-0106
	AMP-0034 (AMC)					29	PCB-0009
7	ELE-0074						

# CARD CAGE ASSEMBLY

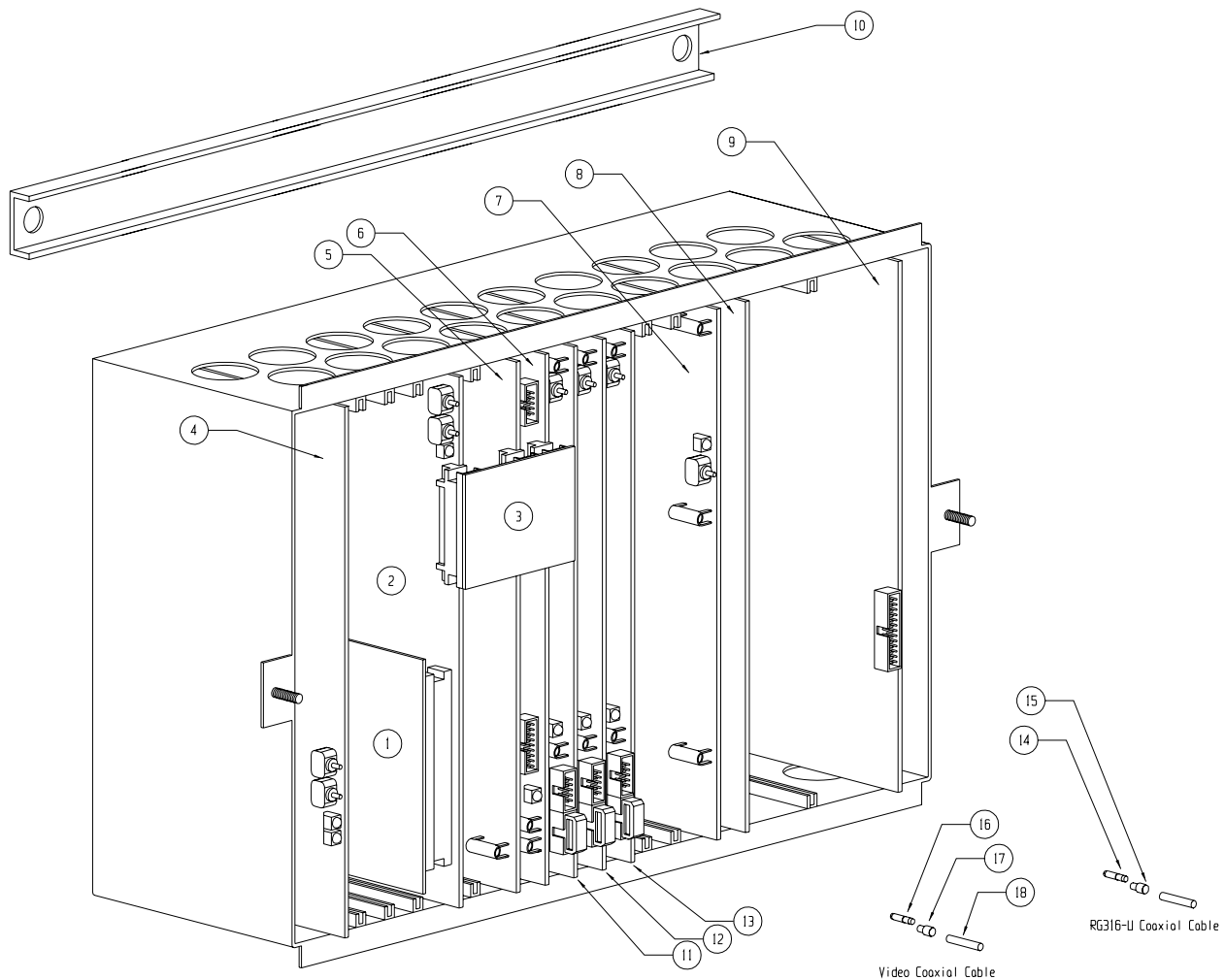

	PART #		PART #
1	PCB-0094	10	STM-0029
2	PCB-0030	11	PCB-0217
3	PCB-0189	12	PCB-0217
4	PCB-0209	13	PCB-0217
5	PCB-0032 (88HS)	14	WIR-0040
	PCB-0033 (32MP)	15	WIR-0041
6	PCB-0206	16	WIR-0038
7	PCB-0141	17	WIR-0039
8	PCB-0000	18	WIR-0086
9	PCB-0009		

SLOT	PART #	BOARD #	SLOT	PART #	BOARD #
1	PCB-0209	1550-2B	10	PCB-0217	1010-6
2			11	PCB-0217	1010-6
3			12		
4	PCB-0189	1730-5	13		
5	PCB-0030	1400-5	14	PCB-0217	1010-6
6			15	PCB-0000	1020
7	PCB-0032	1420-4	16	PCB-0008	1050-3
8	PCB-0206	1030-1	17	PCB-0005	1040
9	PCB-0217	1010-6			

# POWER JUNCTION CABINET ASSEMBLY

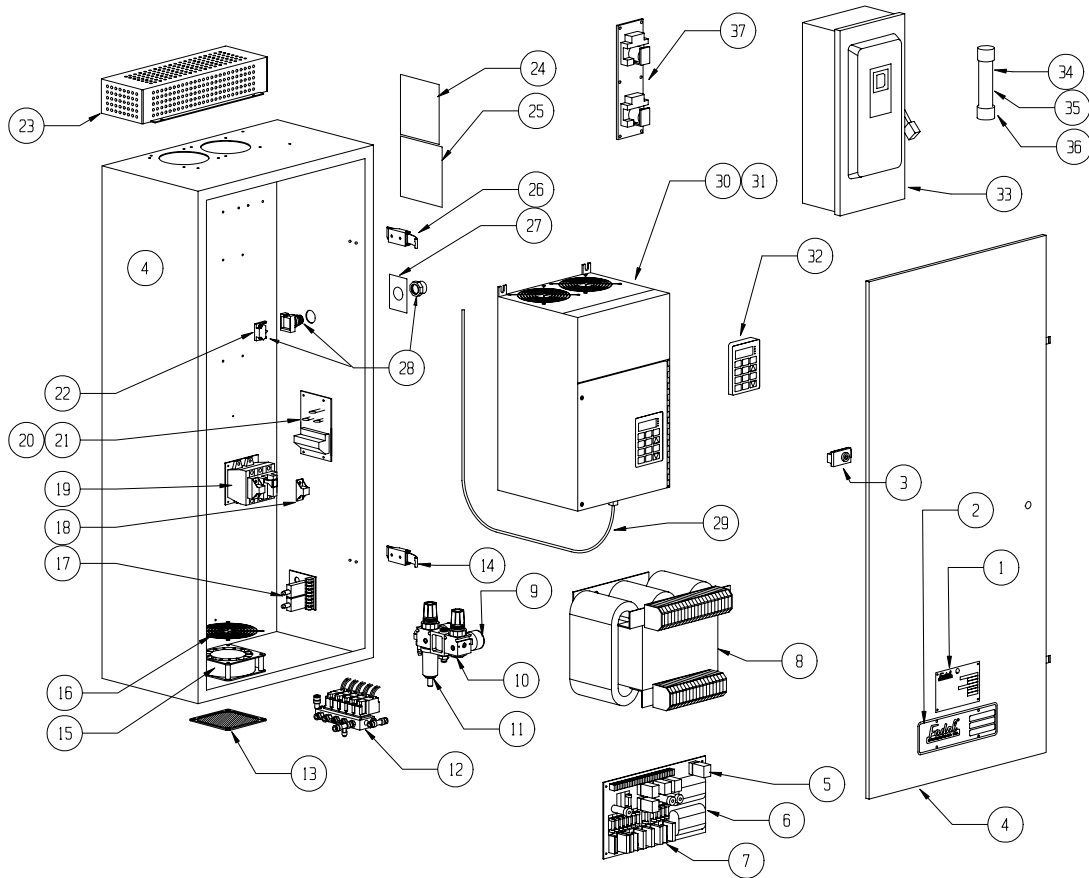

**POWER JUNCTION CABINET ASSEMBLY**

	PART #		PART #		PART #		PART #
1	LBL-0030	12	VLV-0055 (7.5K)	23	INV-0004	33	ELE-0139 (60AMP)
	LBL-0031 (HT)		VLV-0054 (10K)	24	LBL-0037		ELE-0140 (30AMP)
2	LBL-0106	13	HDW-0849	25	LBL-0040	34	ELE-0063 (45A 240V)
3	HDW-0221	14	HDW-0216	26	HDW-0219	35	ELE-0062 (30A 380V)
4	STM-0450	15	ELE-0123	27	LBL-0038	36	ELE-0060 (20A 480V)
5	ELE-0072	16	HDW-0850	28	ELE-0110	37	WIR-0073
6	PCB-0015	17	PCB-0046	29	WIR-0166		
7	ELE-0070	18	ELE-0138	30	INV-0020(HT)		
8	ELE-0200	19	ELE-0132		INV-0041 (Baldor)		
9	REG-0005	20	PCB-0145 (240V)	31	INV-0056 (AMC)		
10	REG-0009	21	PCB-0146 (500V)	32	INV-0017		
11	REG-0008	22	ELE-0093				

# CHILLER CABINET ASSEMBLY

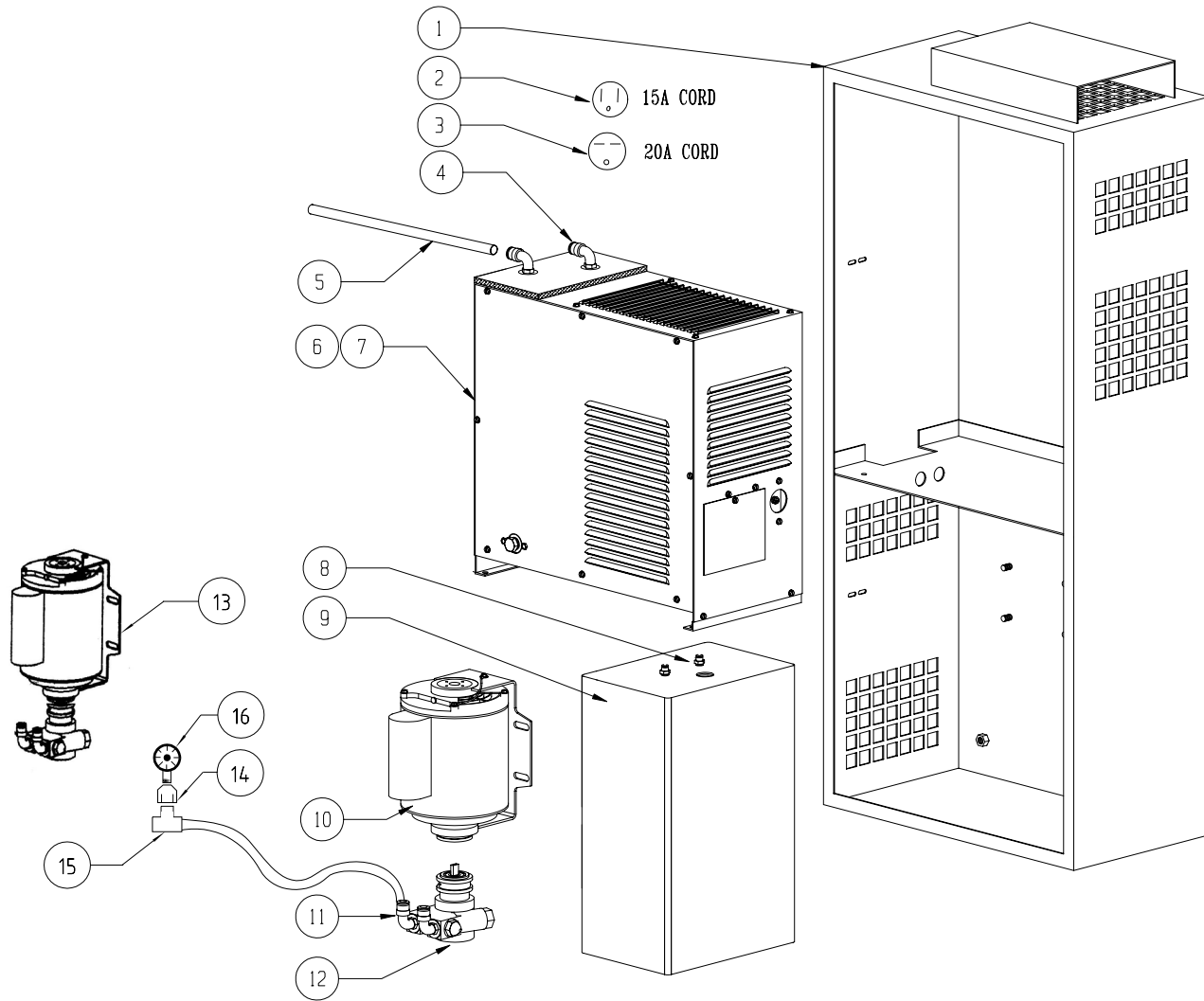

**CHILLER CABINET ASSEMBLY**

	PART #		PART #
1	STM-0125	9	CNT-0047
2	WIR-0433	10	PMP-0029
3	WIR-0434	11	PLM-0042
4	PLM-0042	12	PMP-0000
5	PLM-0024	13	PMP-0034
6	CNT-0035 (15A)	14	PLM-0199
7	CNT-0144 (20A)	15	PLM-0166
8	PLM-0210	16	REG-0017

# MP PENDANT ASSEMBLY

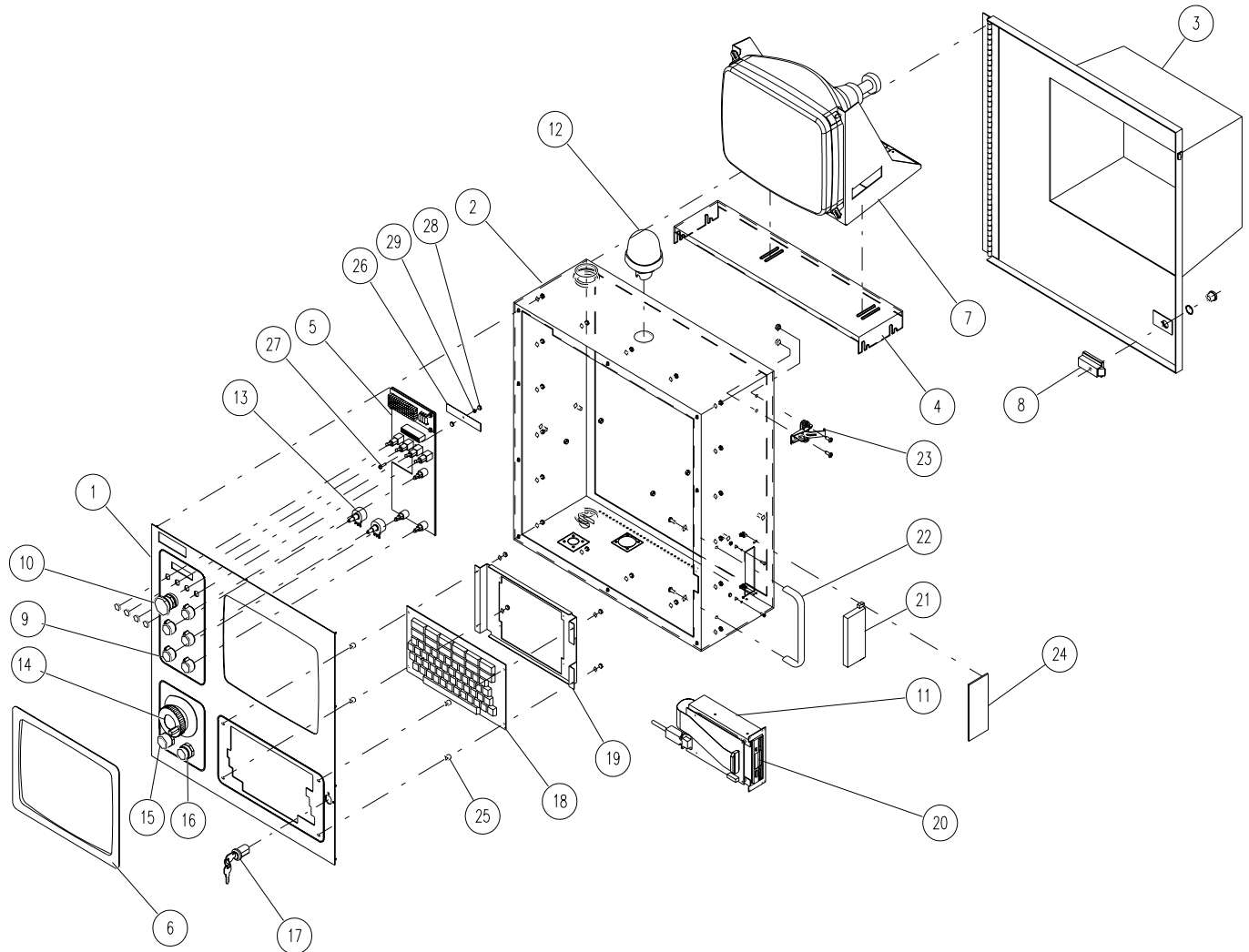

**MP PENDANT ASSEMBLY**

	PART #		PART #		PART #		PART #
1	CTR-0134		ELE-0888	15	ELE-0093	24	STM-0547
2	STM-0945 (2 of 4)		ELE-0889	16	ELE-0091	25	HDW-1083
3	STM-0945 (3 of 4)	8	HDW-0221	17	ELE-0096	26	ELE-1184
4	STM-0951	9	HDW-0621	18	ELE-0083	27	HDW-1082
5	PCB-0200	10	ELE-0673	19	STM-0128	28	HDW-1081
6	CTR-0118	11	STM-0470	20	ELE-0913	29	HDW-0456
	CTR-0136	12	ELE-0969	21	CTR-0014		
	CTR-0135	13	ELE-0380	22	HDW-0182		
7	ELE-1072	14	MPG-0020	23	HDW-0925		

# 88HS PENDANT ASSEMBLY

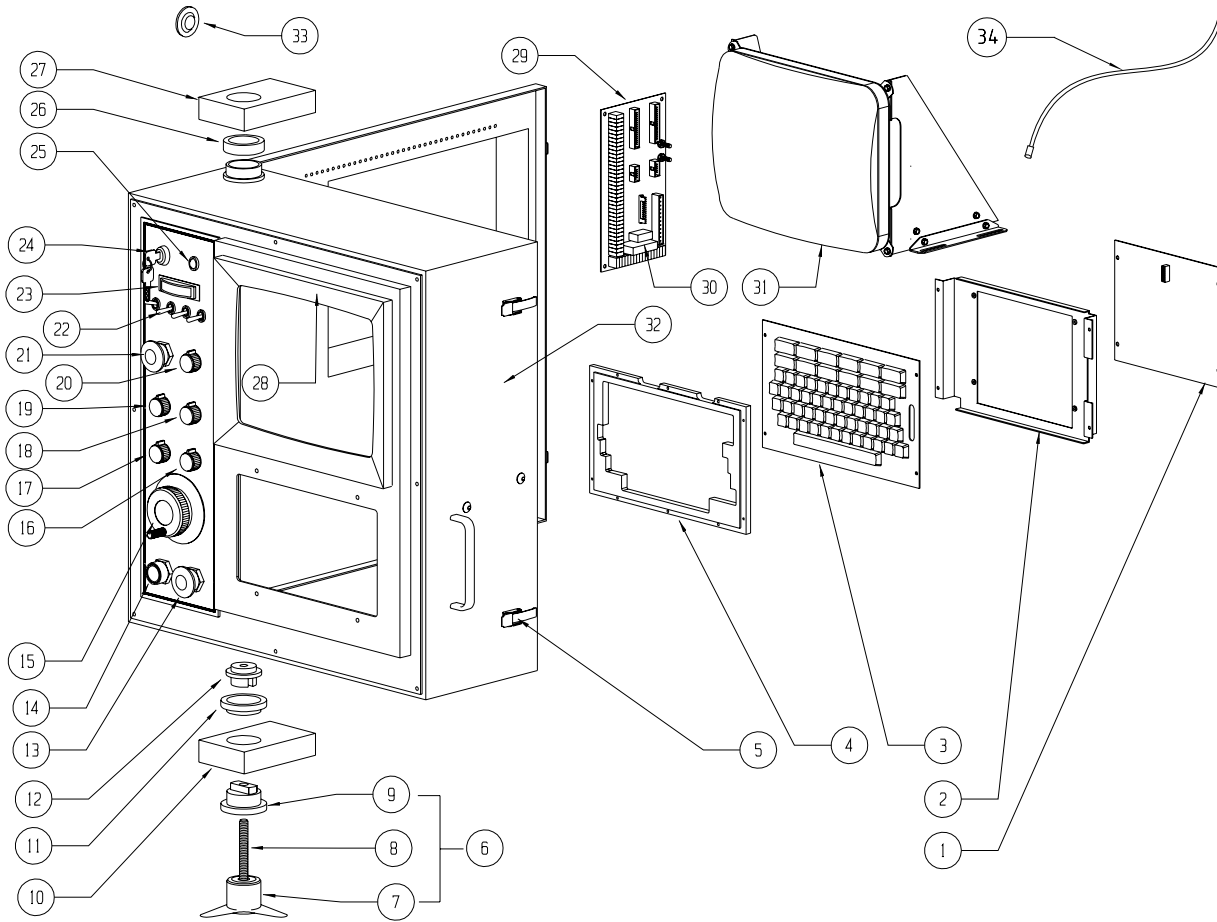

## 88HS PENDANT ASSEMBLY

	PART #		PART #		PART #		PART #
1	PCB-0012	10	CTR-0009	19	ELE-0067	28	HDW-0847
2	STM-0128	11	BRG-0077	20	ELE-0078	29	PCB-0019
3	ELE-0083	12	CTR-0007	21	ELE-0112	30	ELE-0070
4	CTR-0009	13	ELE-0111	22	ELE-0095	31	ELE-0189
5	HDW-0216	14	ELE-0110	23	ELE-0108	32	CTR-0021
6	CTR-0022	15	MPG-0007	24	ELE-0096	33	HDW-0185
7	HDW-0675		MPG-0018	25	ELE-0090	34	WIR-0086
8	CTR-0018	16	ELE-0078	26	HDW-0724		
9	CTR-0008	17	ELE-0081	27	CTR-0006		
		18	ELE-0068				

# FRONT DOOR ASSEMBLY

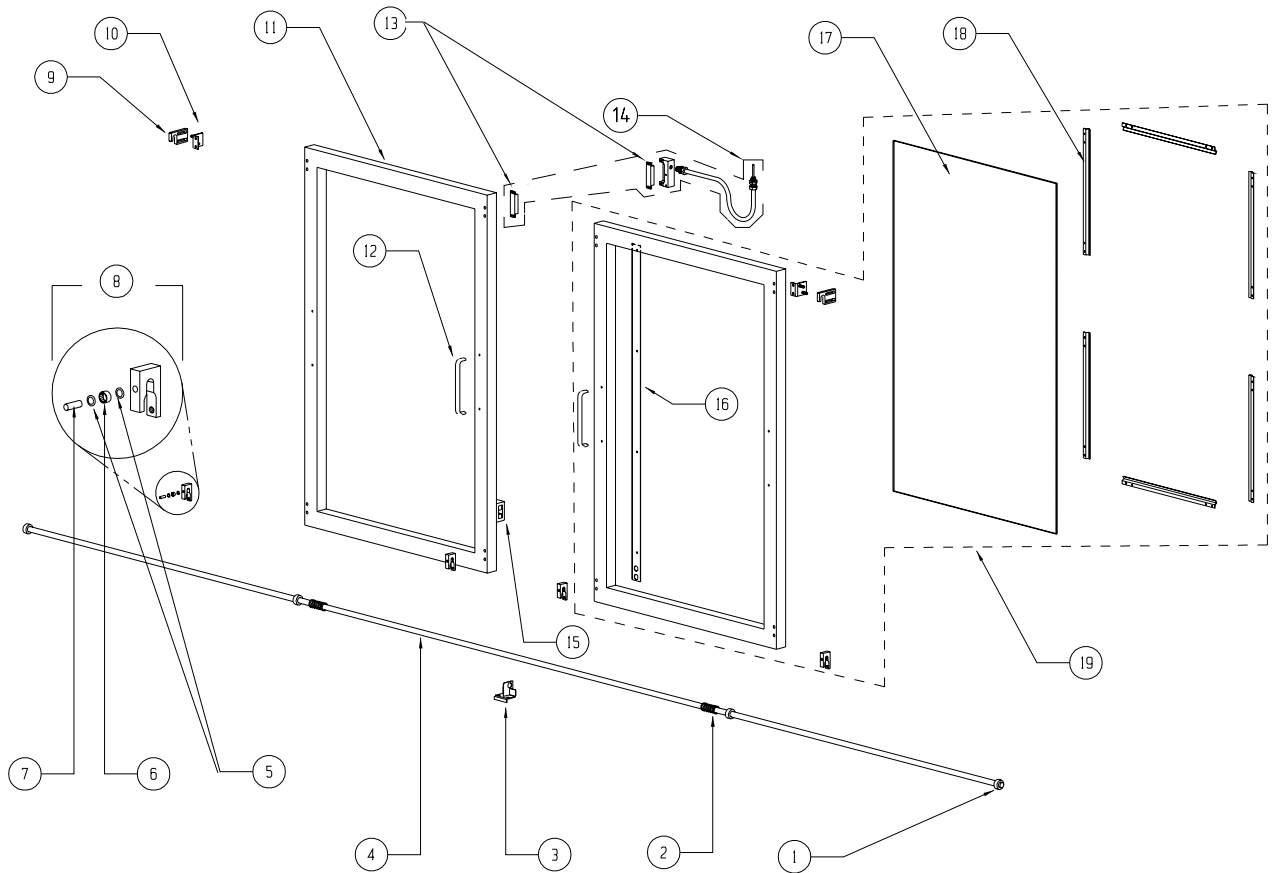

## FRONT DOOR ASSEMBLY

	PART #		PART #		PART #
1	HDW-0215	8	DOR-0016	15	DOR-0035
2	HDW-0264	9	DOR-0001	16	STM-0083
3	DOR-0019	10	DOR-0000	17	DOR-0006
4	DOR-0043	11	DOR-0002	18	STM-0084
5	HDW-0149	12	HDW-0182	19	DOR-0027
6	BRG-0014	13	ELE-0810 <sup>(1)</sup>		
7	HDW-0327	14	WIR-0069 <sup>(2)</sup>		

<sup>1</sup>Set of two sensors

<sup>2</sup>Includes set of two sensors and one block cable

# WAY COVER ASSEMBLY

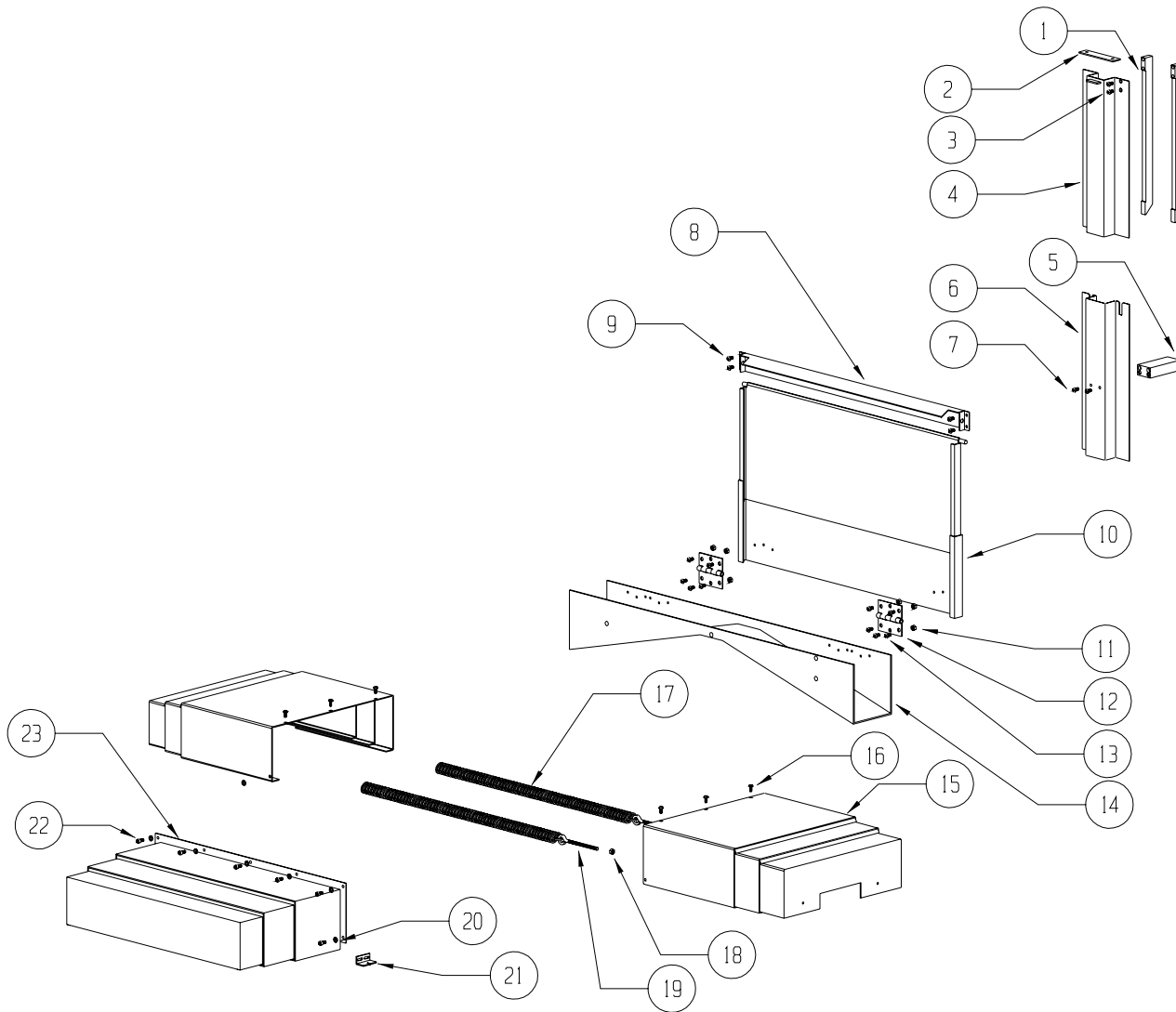

## WAY COVER ASSEMBLIES

	PART #		PART #		PART #
1	CVR-0031	9	HDW-0346	17	HDW-0261
2	CVR-0030	10	CVR-0056	18	HDW-0336
3	HDW-0319	11	HDW-0339	19	HDW-0251
4	CVR-0034	12	HDW-0192	20	HDW-0279
5	CVR-0036	13	HDW-0324	21	STM-0047
6	CVR-0035	14	STM-0053	22	HDW-0482
7	HDW-0346	15	CVR-0017	23	CVR-0021
8	STM-0066	16	HDW-0347		



# SHEETMETAL HOUSING

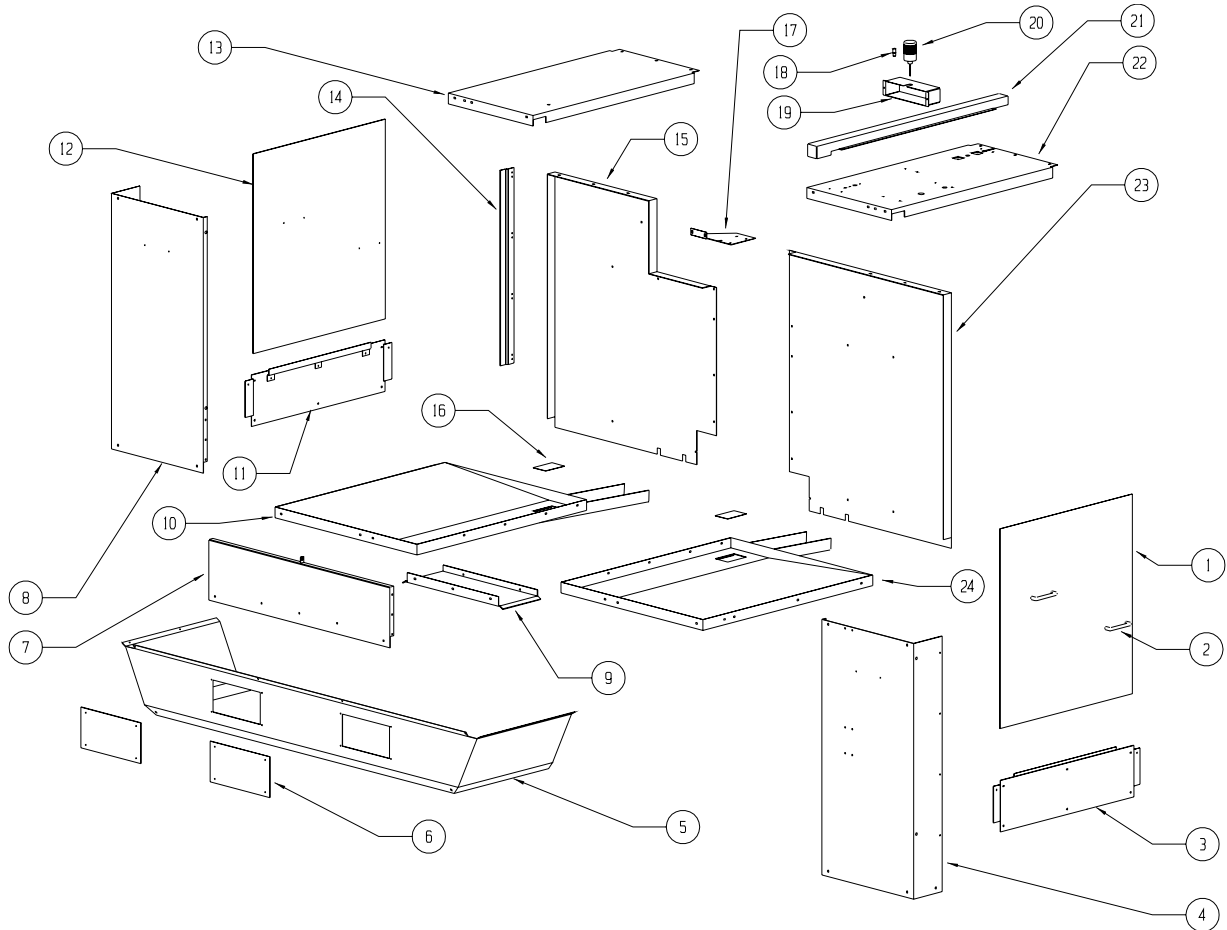

## SHEETMETAL HOUSING

	PART #		PART #		PART #
1	STM-0241	9	STM-0108	17	STM-0540
2	HDW-0181	10	STM-0321	18	ELE-0122
3	STM-0240	11	STM-0240	19	STM-0088
4	STM-0247	12	STM-0241	20	ELE-0121
5	STM-0238	13	STM-0256	21	STM-0085
6	STM-0299	14	STM-0244	22	STM-0255
7	STM-0078	15	STM-0322	23	STM-0324
8	STM-0344	16	STM-0110	24	STM-0323

# 7500 RPM COOLANT TANK

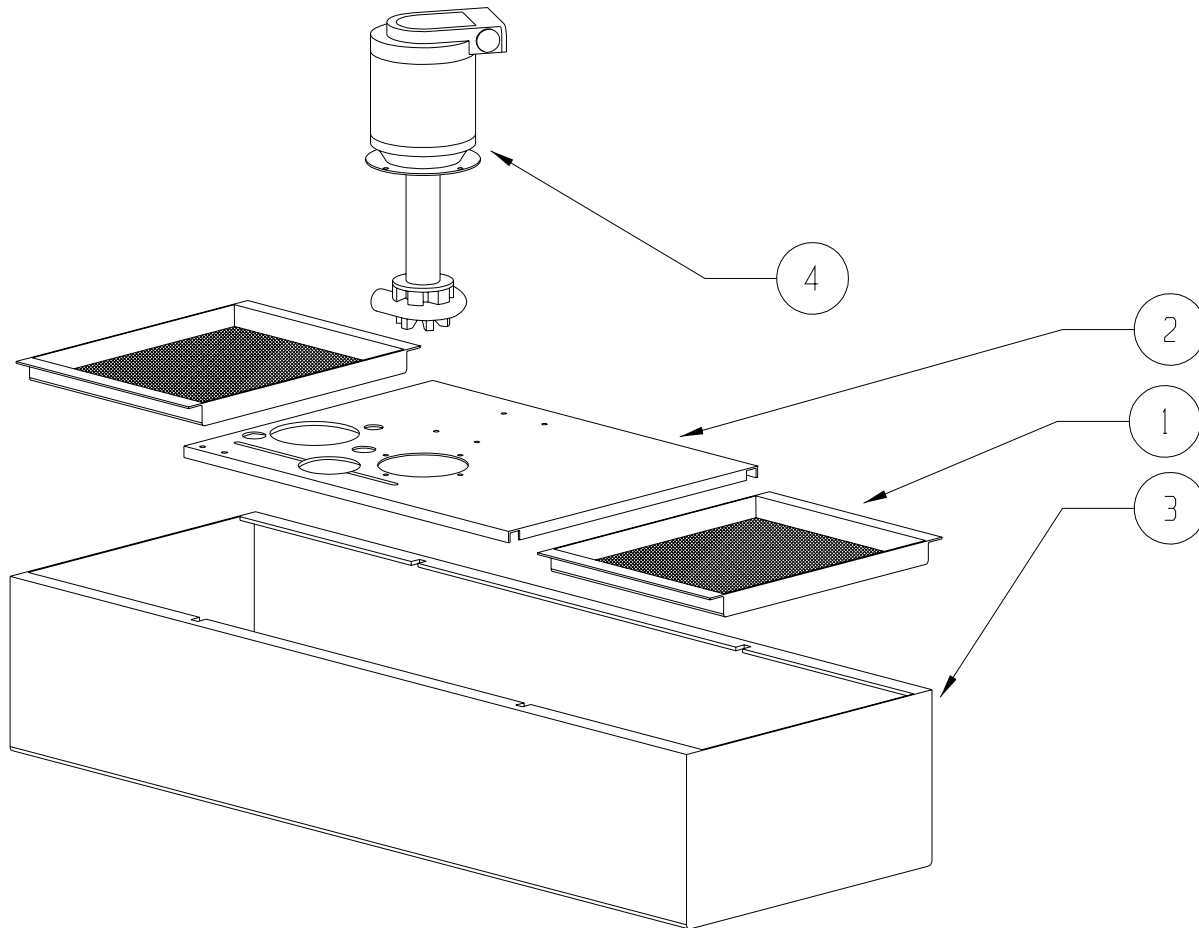

**7500 RPM COOLANT TANK**

	PART #
1	STM-0116
2	STM-0594
3	STM-0287
4	PMP-0017

# 7500 RPM COOLANT THROUGH TANK

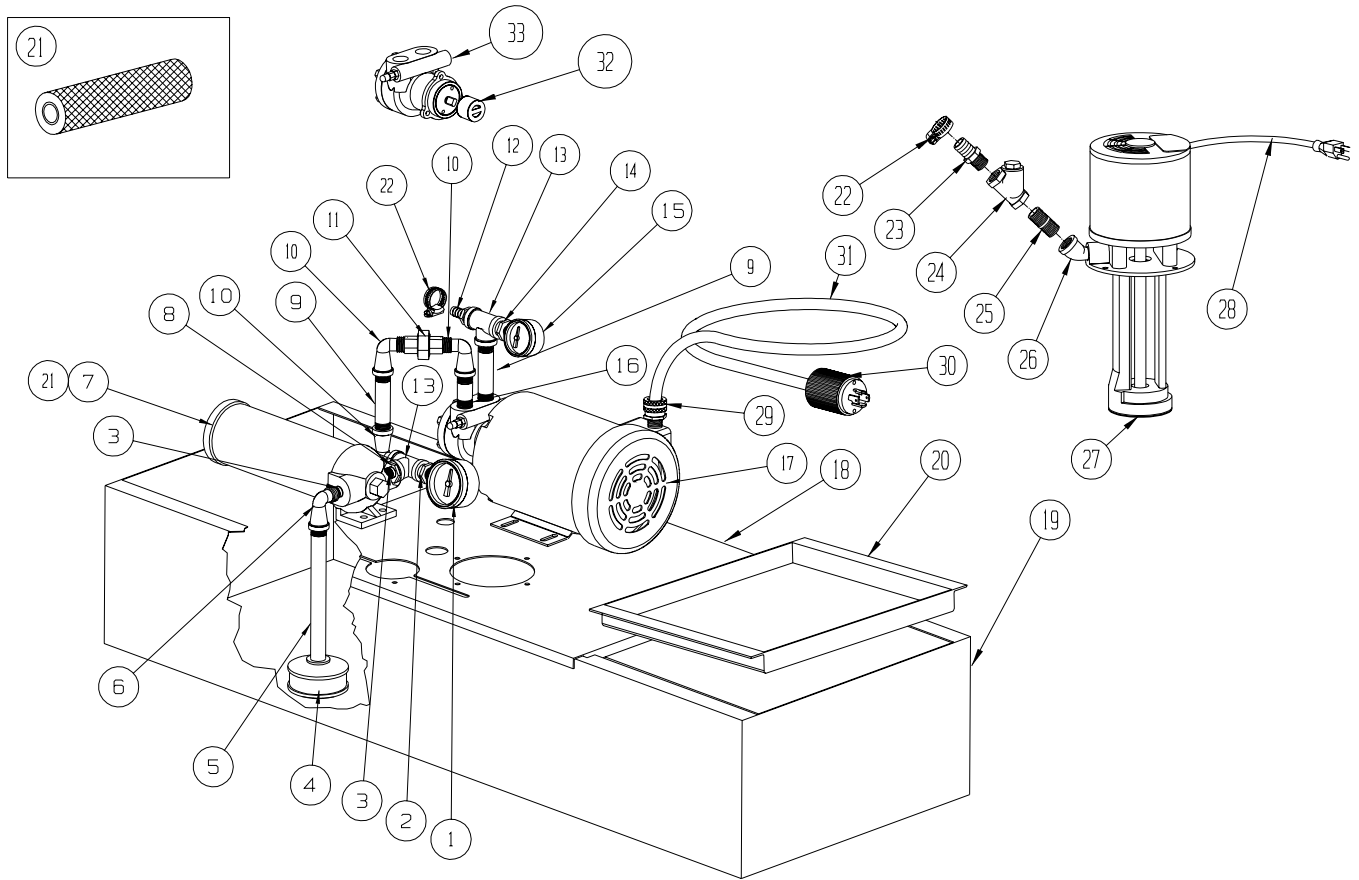

**7500 RPM COOLANT THROUGH TANK ASSEMBLY**

	PART #		PART #		PART #		PART #
1	REG-0034	11	PLM-0212	21	CNT-0029 <sup>(1)</sup>	31	WIR-0536
2	PLM-0216	12	PLM-0104	22	HDW-0252	32	PMP-0019
3	PLM-0117	13	PLM-0089	23	PLM-0067	33	PMP-0007
4	CNT-0025	14	PLM-0217	24	VLV-0018		
5	PLM-0213	15	REG-0018	25	PLM-0092		
6	PLM-0100	16	PLM-0060	26	PLM-0099		
7	CNT-0027 <sup>(1)</sup>	17	PMP-0008	27	PMP-0017		
8	HDW-0391	18	STM-0594	28	WIR-0096		
9	PLM-0061	19	STM-0287	29	WIR-0517		
10	PLM-0215	20	STM-0116	30	WIR-0535		

<sup>1</sup>Filter (CNT-0029) fits inside filter housing (CNT-0027).

# 10K RPM COOLANT TANK

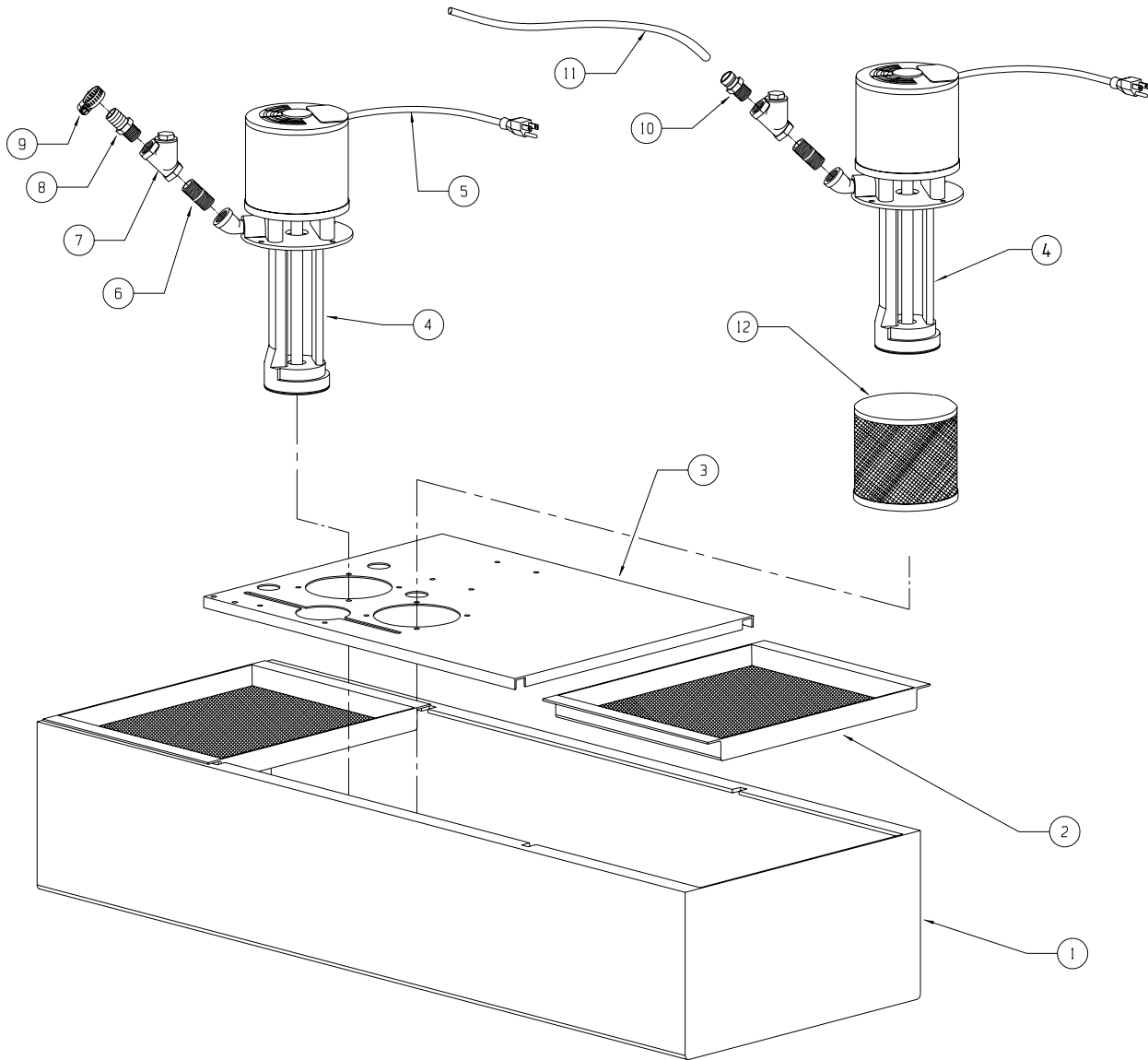

**10,000 RPM COOLANT TANK**

	PART #		PART #		PART #
1	STM-0287	5	WIR-0096	9	HDW-0252
2	STM-0116	6	PLM-0092	10	PLM-0043
3	STM-0594	7	VLV-0018	11	PLM-0023
4	PMP-0017	8	PLM-0067	12	CNT-0026

# 10K RPM COOLANT THROUGH TANK

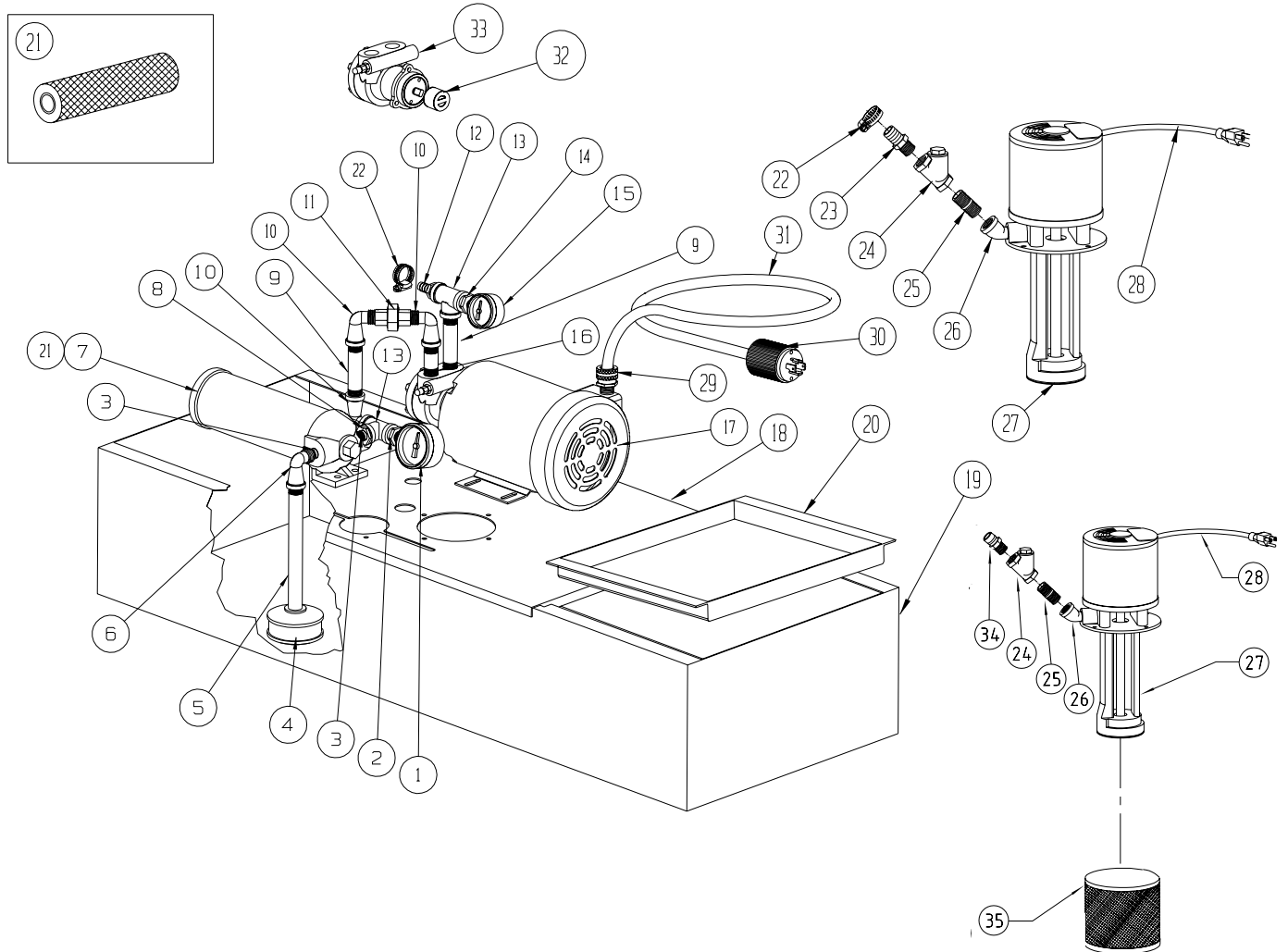

**10,000 RPM COOLANT THROUGH TANK ASSEMBLY**

	PART #		PART #		PART #		PART #		PART #
1	REG-0034	9	PLM-0061	17	PMP-0008	25	PLM-0092	33	PMP-0007
2	PLM-0216	10	PLM-0215	18	STM-0594	26	PLM-0099	34	PLM-0043
3	STM-0594	11	PLM-0212	19	STM-0287	27	PMP-0017	35	CNT-0026
4	CNT-0025	12	PLM-0104	20	STM-0116	28	WIR-0096		
5	PLM-0213	13	PLM-0089	21	CNT-0029 <sup>(1)</sup>	29	WIR-0517		
6	PLM-0100	14	PLM-0217	22	HDW-0252	30	WIR-0535		
7	CNT-0027 <sup>(1)</sup>	15	REG-0018	23	PLM-0067	31	WIR-0536		
8	HDW-0391	16	PLM-0060	24	VLV-0018	32	PMP-0019		

<sup>1</sup>Filter (CNT-0029) fits inside filter housing (CNT-0027).